

Rev	Description	Date	By
A	INITIAL RELEASE	09/15/05	JSC

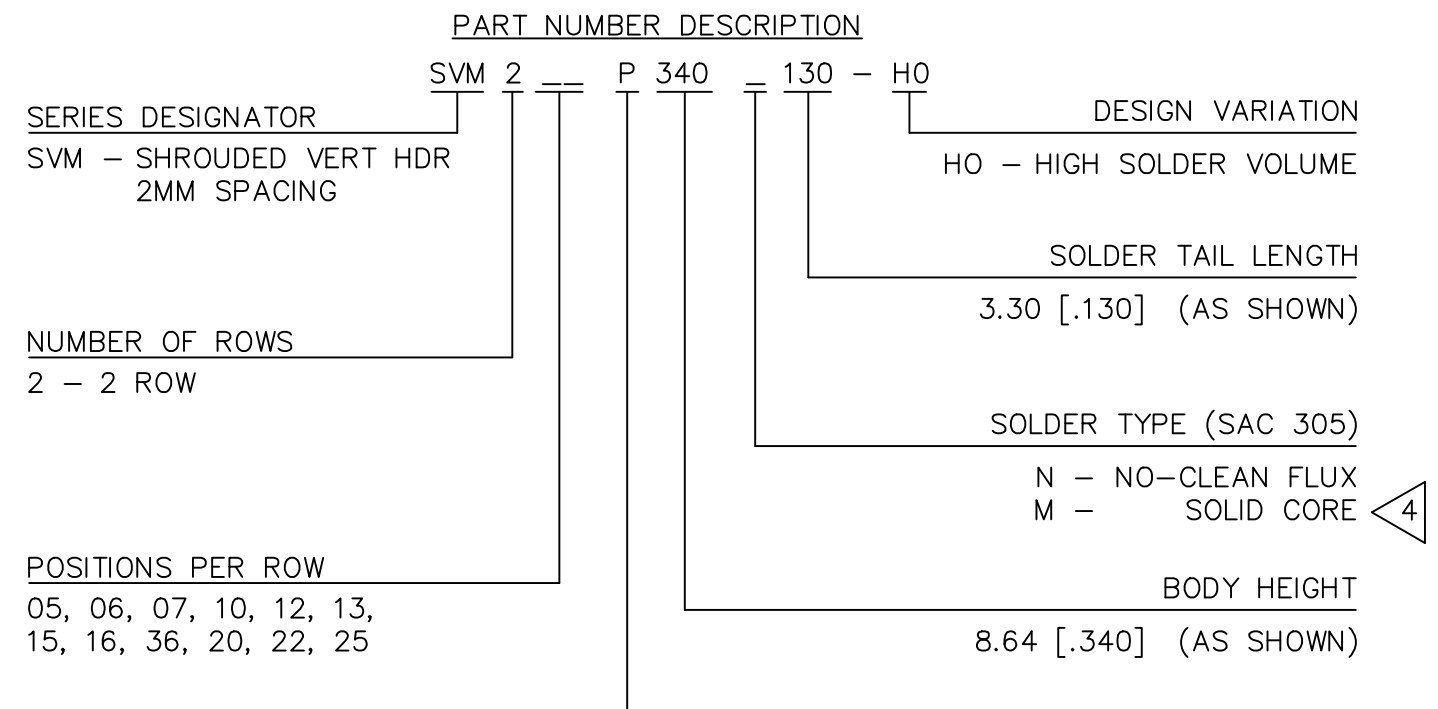

CONTACT FINISH DESIGNATION		
DESIGNATION	MATING ZONE	SOLDER TAIL
B	GOLD - 10 MICROINCHES	PURE TIN - 100 MICROINCHES

NOTES: UNLESS OTHERWISE SPECIFIED

- INTERPRET THIS DRAWING IN ACCORDANCE WITH ASME Y14.5M - 1994
- FOR OTHER SIZES, FINISHES, SOLDER VOLUMES OR ADDITIONAL DATA CONSULT TEKA CUSTOMER SERVICE DEPARTMENT
- CONNECTOR SOLDER VOLUME BASED ON APPLICATION  $2.36 \pm 0.25$  [.093 ± .010] PCB
- UPPER WAFER REQUIRED TO CONTAIN NO CLEAN FLUX IN ORDER TO ENABLE SOLDER PASS-THROUGH
- ALL TIN FINISHES ARE LOW STRESS / WHISKER MITIGATING

MATERIALS:

HOUSING: HIGH TEMPERATURE THERMOPLASTIC, UL RATED 94-V0

CONTACT: COPPER ALLOY

SOLDER: SEE PART NUMBER DESCRIPTION

CONTACT FINISH: (SEE PART NUMBER DESCRIPTION)

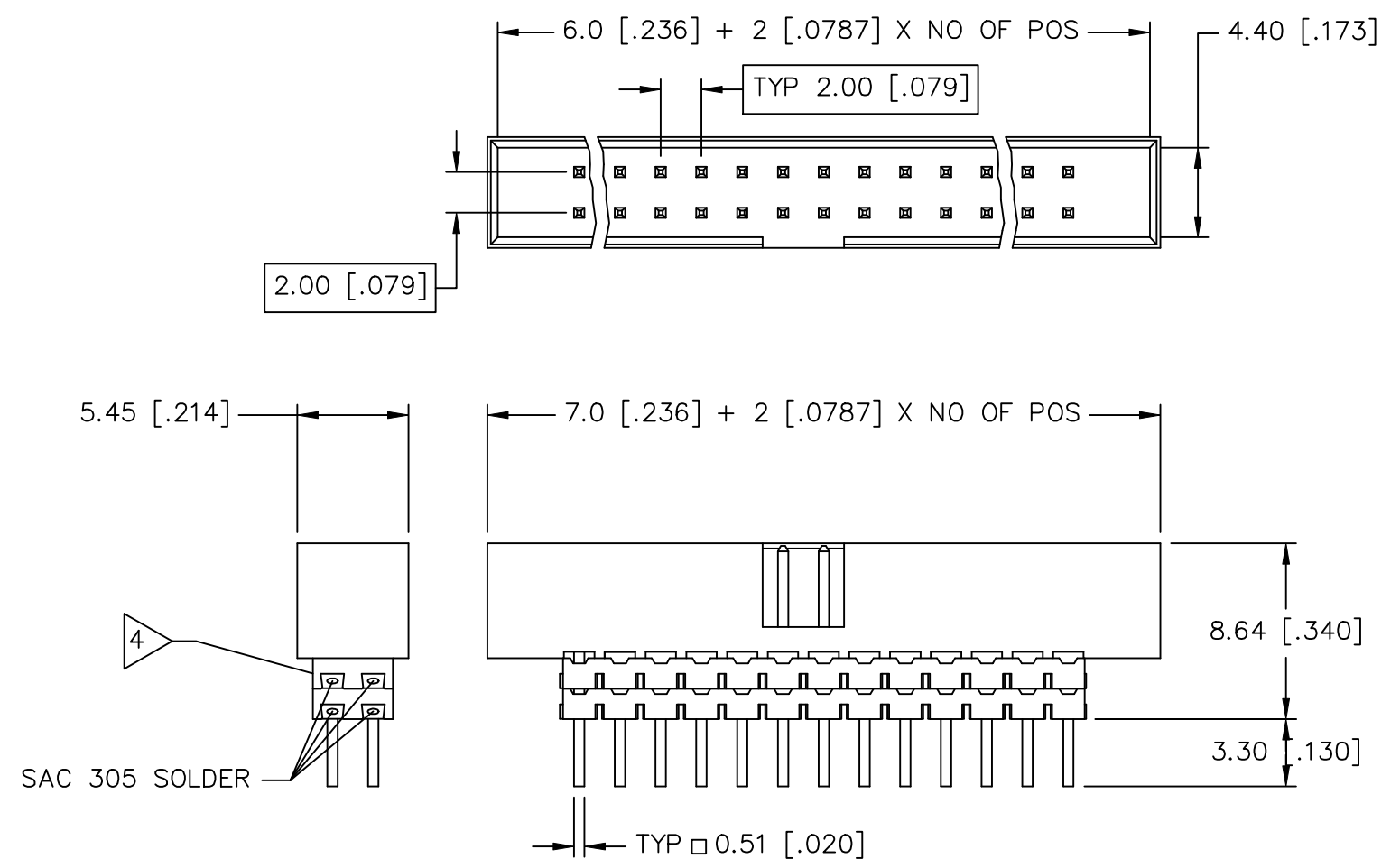
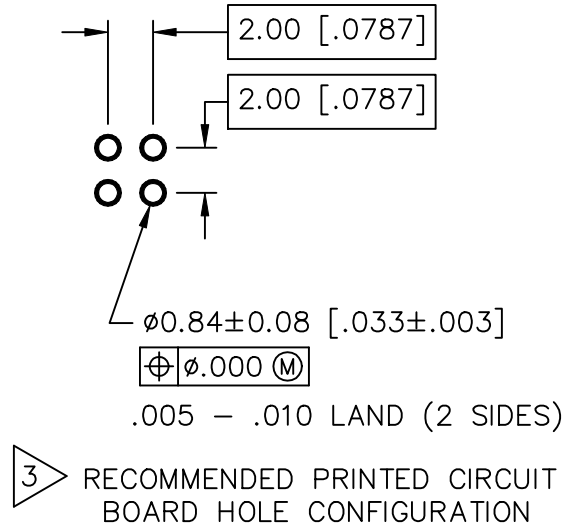

Unless otherwise specified: All dimensions are: mm [Inches]	Drawn by: J CACHINA	Date: 05/15/05	 AN INTERPLEX INDUSTRIES CO. 100 PIONEER AVE WARWICK, R.I. 02888 TEL: (401) 785-4110 FAX: (401) 781-5730 E-MAIL: sales@tekais.com
	Checked by: JSC	Date: 05/15/05	
-Tolerances-	Title: SB 2MM SHROUDED VERT HDR (ROHS COMPLIANT)		Part No: SVM2__B340_130-HO
No of places mm [IN]	Ref No: S20550		Scale: 3:1
one ±0,5 ±.020			Sheet 1 of 1
two ±0,25 ±.010			
three ±0,13 ±.005			
Angular ±2°			