

Rev	Description	Date	By
A	INITIAL RELEASE	09/15/05	JSC

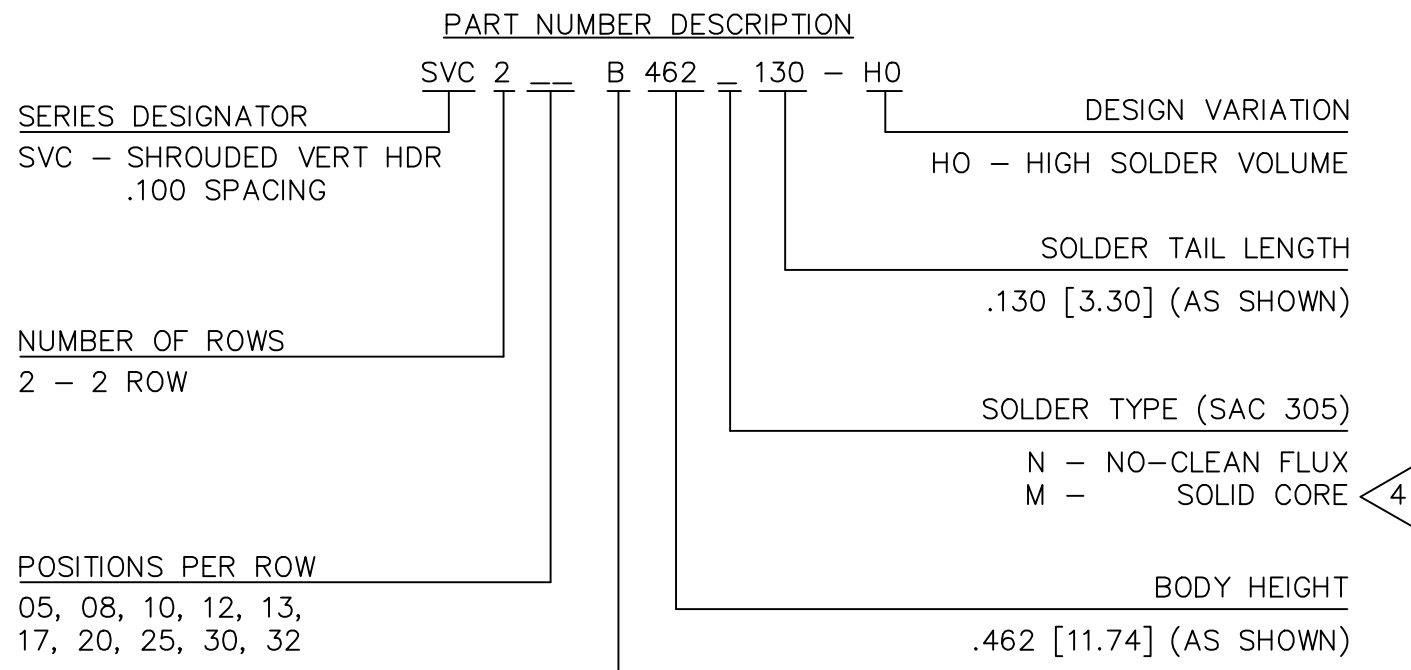

CONTACT FINISH DESIGNATION		
DESIGNATION	MATING ZONE	SOLDER TAIL
B	GOLD - 10 MICROINCHES	PURE TIN - 100 MICROINCHES

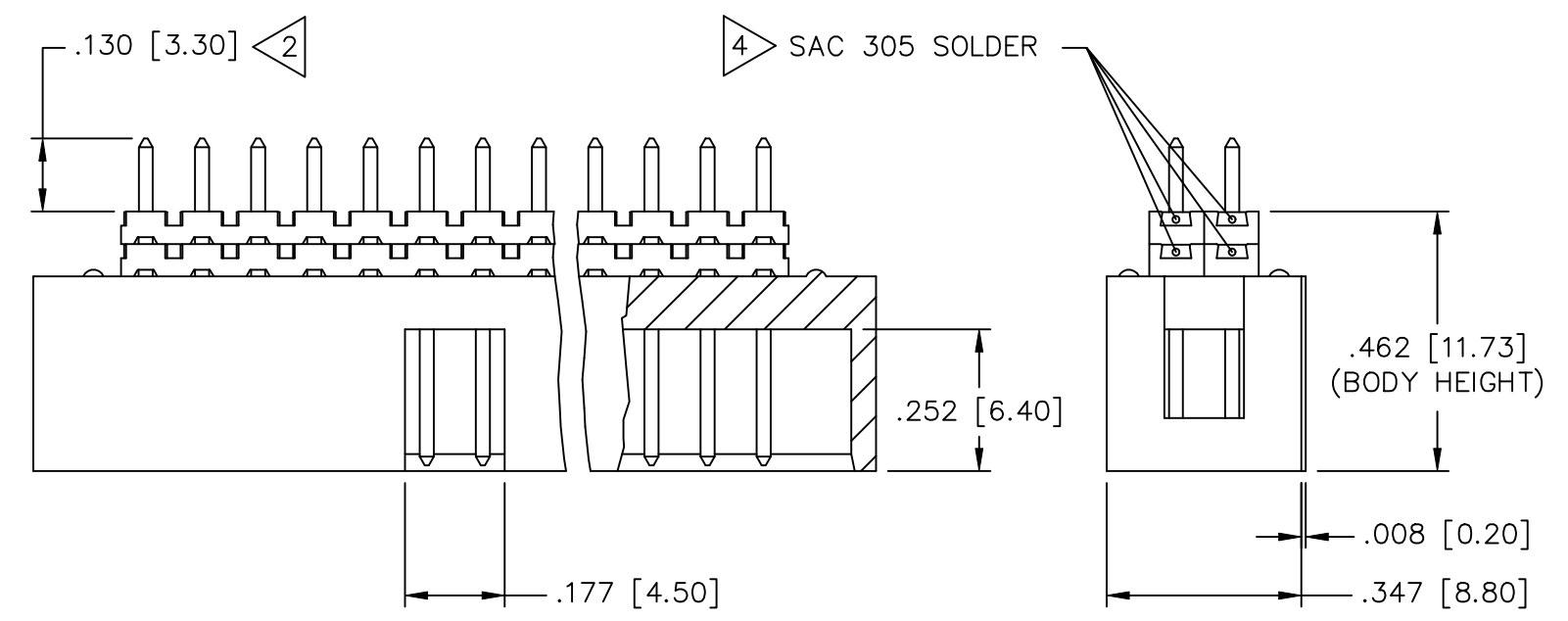

NOTES: UNLESS OTHERWISE SPECIFIED

- 1 INTERPRET THIS DRAWING IN ACCORDANCE WITH ASME Y14.5M - 1994
- 2 FOR OTHER SIZES, FINISHES, SOLDER TAIL LENGTHS OR ADDITIONAL DATA CONSULT TEKA CUSTOMER SERVICE
- 3 CONNECTOR SOLDER VOLUME BASED ON APPLICATION .093±.010 [2.36±0.25] PCB
- 4 WAFER MOST PROXIMATE TO REQUIRED TO CONTAIN NO CLEAN FLUX IN ORDER TO ENABLE SOLDER PASS-THROUGH
- 5 ALL TIN FINISHES ARE LOW STRESS / WHISKER MITIGATING

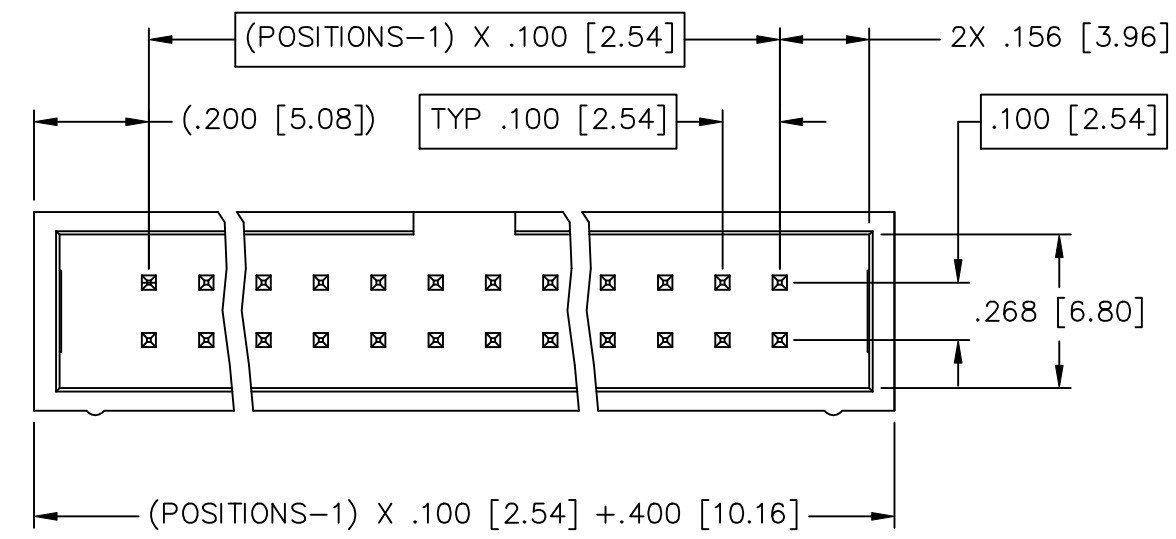

MATERIALS:

HOUSING: HIGH TEMPERATURE THERMOPLASTIC, UL RATED 94-V0

CONTACT: COPPER ALLOY

SOLDER: SEE PART NUMBER DESCRIPTION

CONTACT FINISH: (SEE PART NUMBER DESCRIPTION)

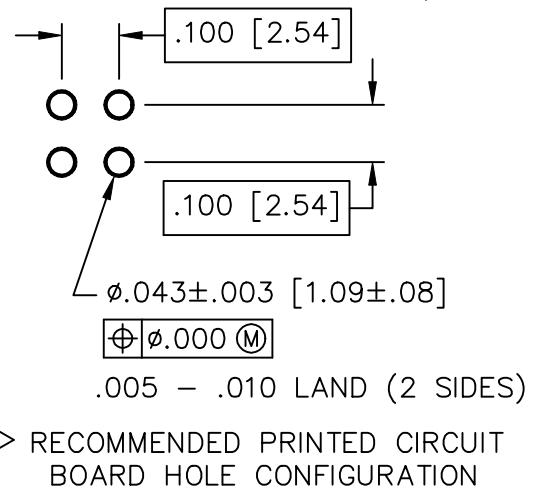

Unless otherwise specified: All dimensions are: Inches [mm]	Drawn by: J CACHINA	Date: 09/15/05	 AN INTERPLEX INDUSTRIES CO. 100 PIONEER AVE WARWICK, R.I. 02888 TEL: (401) 785-4110 FAX: (401) 781-5730 E-MAIL: sales@tekais.com <a href="http://www.tekais.com">HTTP://WWW.TEK AIS.COM</a>
	Checked by: JSC Date: 09/15/05		
-Tolerances-	Title: SB SHROUDED VERT HDR -.100 [2.54] PITCH (ROHS COMPLIANT)		Part No: SVC2__B462_130-HO
No of places IN [mm]	Ref No: S20551		Scale: 3:1 Sheet 1 of 1
one ±.1 ±2,54			
two ±.02 ±0,5			
three ±.010 ±0,25			
Angular ±2°			