

Rev	Description	Date	By
A	INITIAL RELEASE	09/15/05	JSC

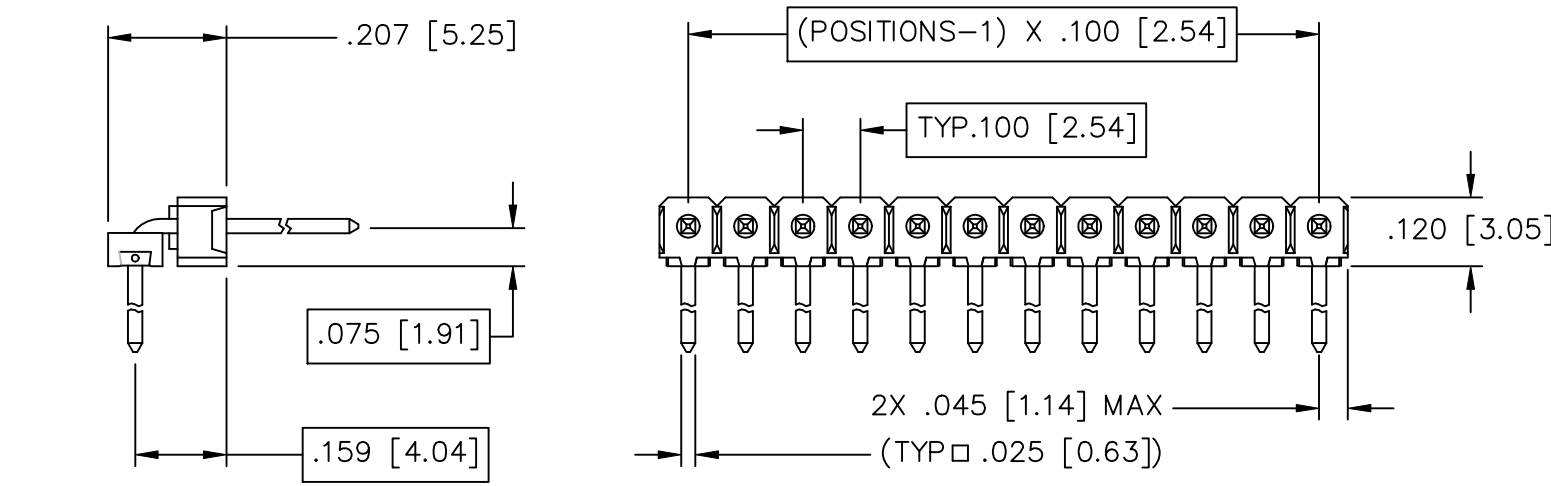
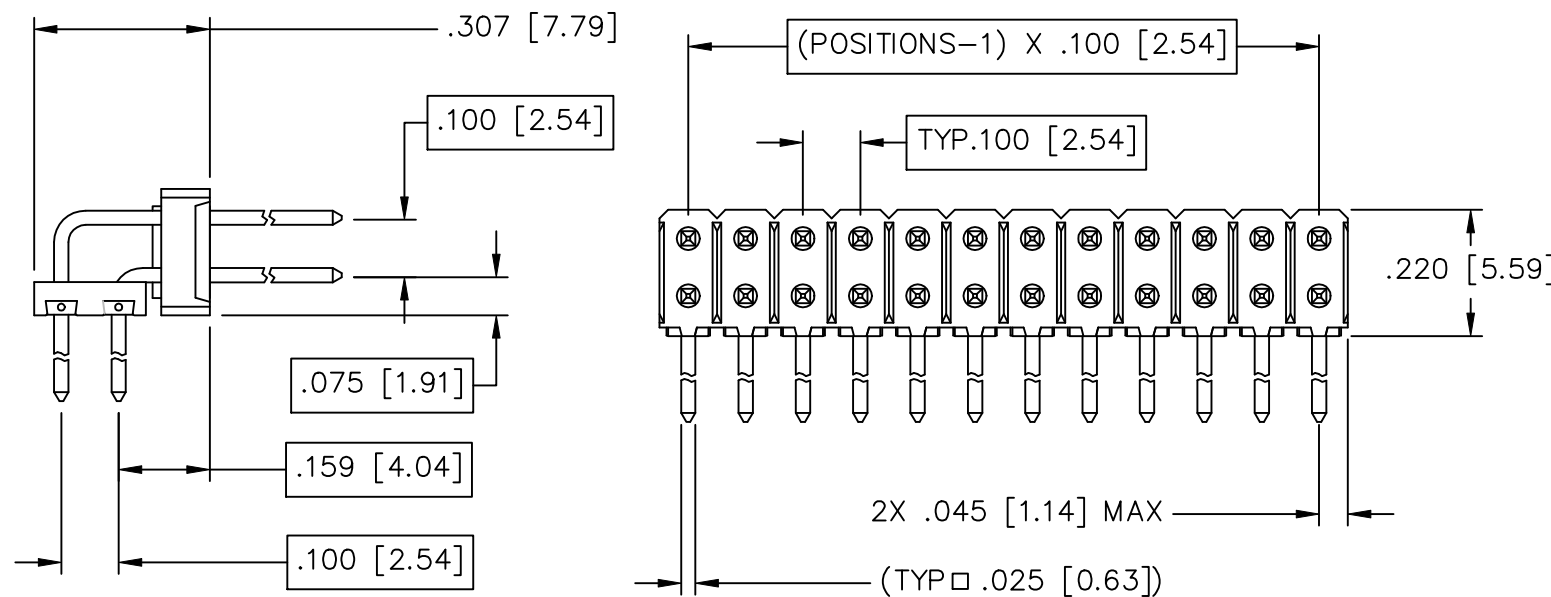

**PART NUMBER DESCRIPTION**

SERIES DESIGNATOR: HR

HEADER R/A - .100

NUMBER OF ROWS: 1 - 1 ROW, 2 - 2 ROW

POSITIONS PER ROW: 02 - 36

POST LENGTH: A - .230 [5.84], B - .320 [8.13], C - .275 [7.00]

MATING ZONE LENGTH: 1 - .165 [4.19]

DESIGN VARIATION: 00 - STANDARD

SOLDER TAIL STYLE: S - STRAIGHT, R - RETENTIVE

SOLDER TYPE (SAC 305): N - NO-CLEAN FLUX, M - SOLID CORE

SOLDER TAIL LENGTH: A - .090 [2.29], B - .136 [3.45], C - .110 [2.79]

CONTACT FINISH DESIGNATION		
DESIGNATION	MATING ZONE	SOLDER TAIL
C	GOLD - FLASH	PURE TIN - 100 MICROINCHES
B	GOLD - 10 MICROINCHES	PURE TIN - 100 MICROINCHES
H	GOLD - 30 MICROINCHES	PURE TIN - 100 MICROINCHES
0	PURE TIN - 100 MICROINCHES	PURE TIN - 100 MICROINCHES

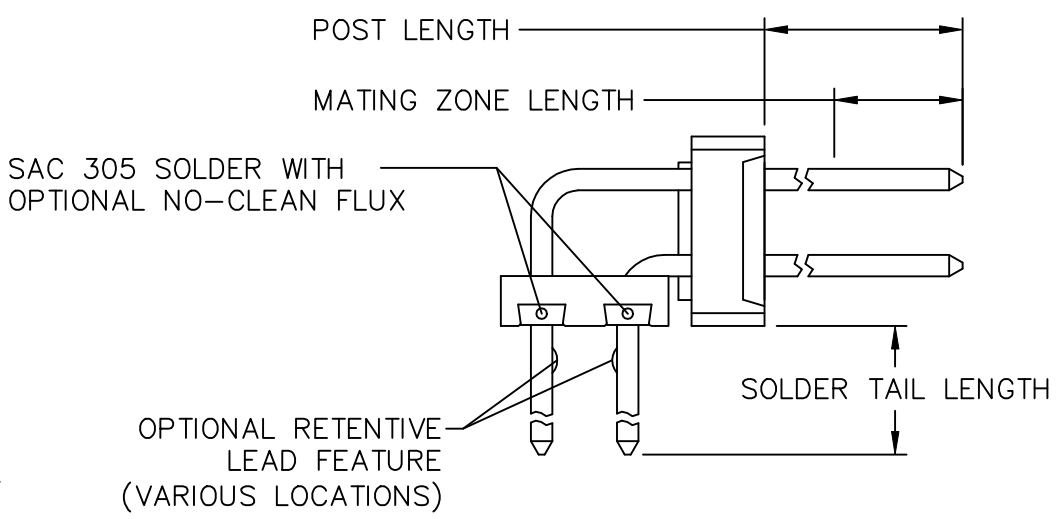

**NOTES: UNLESS OTHERWISE SPECIFIED**

- 1 INTERPRET THIS DRAWING IN ACCORDANCE WITH ASME Y14.5M - 1994
- 2 FOR OTHER SIZES, FINISHES, SOLDER VOLUMES OR ADDITIONAL DATA CONSULT TEKA CUSTOMER SERVICE DEPARTMENT
- 3 CONNECTOR SOLDER VOLUME BASED ON APPLICATION TO A .062±.007 [1.58±0.18] THICK PRINTED CIRCUIT BOARD
- 4 ALL TIN FINISHES SHOWN ARE LOW STRESS / WHISKER MITIGATING

**MATERIALS:**

HOUSING: HIGH TEMPERATURE THERMOPLASTIC, UL RATED 94-V0

CONTACT: COPPER ALLOY

SOLDER: SEE PART NUMBER DESCRIPTION

CONTACT FINISH: SEE PART NUMBER DESCRIPTION

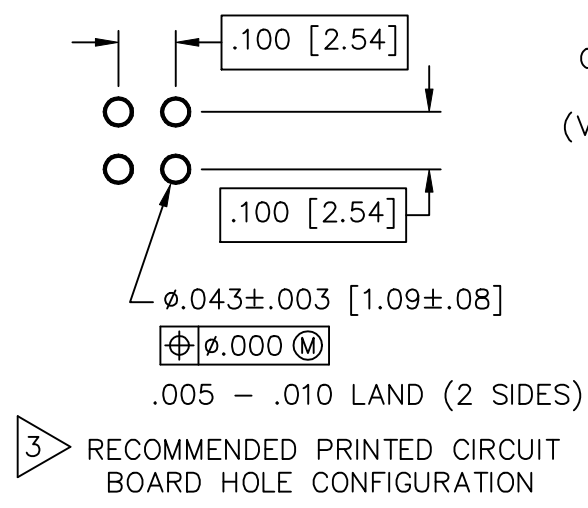

Unless otherwise specified: All dimensions are: Inches [mm]	Drawn by: J CACHINA	Date: 09/15/05	 AN INTERPLEX INDUSTRIES CO. 100 PIONEER AVE WARWICK, R.I. 02888 TEL: (401) 785-4110 FAX: (401) 781-5730 E-MAIL: sales@tekais.com
-Tolerances-	Checked by: JSC	Date: 09/15/05	
No of places IN [mm]	Title: R/A SB HEADER - .100 [2.54] PITCH (ROHS COMPLIANT)		Part No: HR____1____-00
one ±.1 ±2,54	Ref No: S20559		Scale: 3:1
two ±.02 ±0,5			Sheet 1 of 1
three ±.010 ±0,25			
Angular ±2°			