

NOTES:

1. MATERIAL:

INSULATOR MATERIAL - GLASS FILLED THERMO-PLASTIC
 POLYESTER, 94V-0 RATED, BLACK.
 CONTACT MATERIAL - CDA 510.
 CONTACT PLATING - .000030 Au OVER .000050 Ni ON
 CONTACT POINT, TAIL AND COMPLANT SECTION .000100
 MATTE FINISH 60/40 SnPb.

2. ELECTRICAL CHARACTERISTICS:

CONTACT RESISTANCE:
 CONTACT TO DAUGHTER CARD - 10 MILLIOHMS.
 DIELECTRIC WITHSTANDING VOLTAGE - 1800 VAC.
 INSULATION RESISTANCE - 5000 MEGOHMS.
 CONTACT CURRENT RATING - 3 AMPS AT 30°C.

3. MECHANICAL CHARACTERISTICS:

OPERATING TEMPERATURE - -55° TO +125°C.
 DURABILITY - PER BELLCORE TR-NWT-000078.

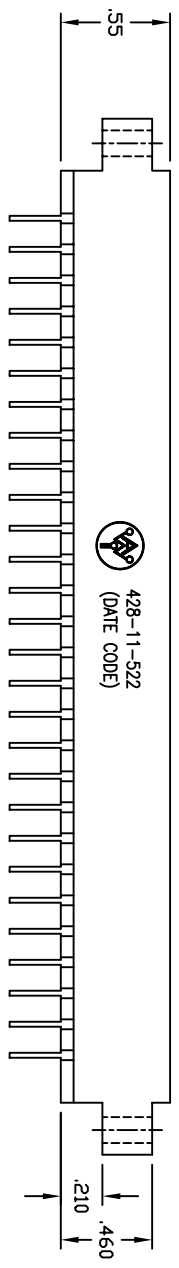
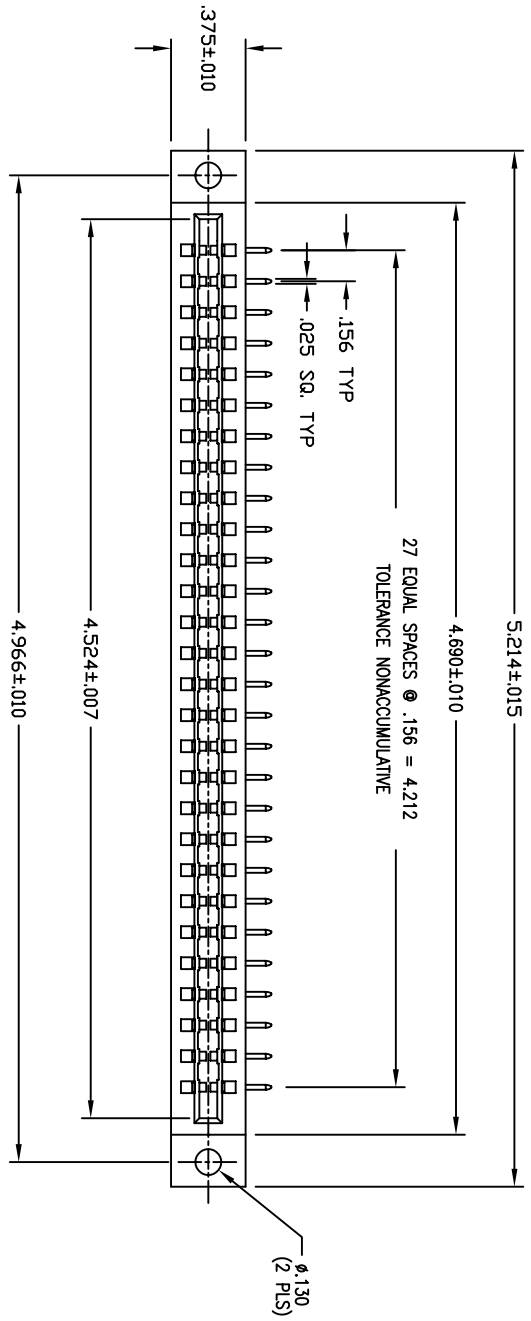
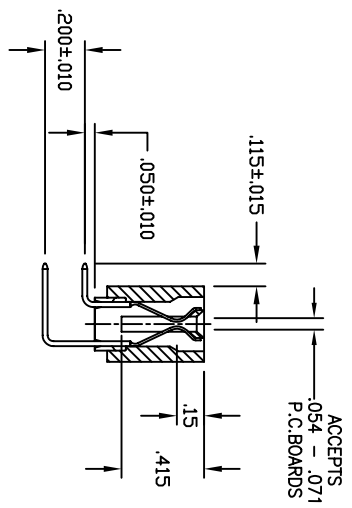

REVISIONS			
REV	DESCRIPTION	DATE	APPROVED
A	INITIAL RELEASE (ESR 0636)	10-29-96	JWM

APPROVED	
NAME	DATE
DRWEN JWM	10-96
CHECKED YL	10-96
QUALITY WBK	10-96
APPROVED JWM	10-96

THE INFORMATION, DATA AND/OR SERVICES CONTAINED ON THIS DRAWING ARE PROPRIETARY TO A.W. INDUSTRIES AND MAY NOT BE COPIED, REPRODUCED OR DISCLOSED IN ANY MANNER WITHOUT THE WRITTEN PERMISSION OF A.W. INDUSTRIES.

ALL DIMENSIONS ARE IN INCHES.
 TOLERANCES:
 DECIMAL .XX ±.015
 .XXX ±.005
 ANGLE ±1/2°

TITLE
 .156 CENTERS CARD EDGE CONNECTOR
 28 POSITIONS-RIGHT ANGLE ON .200 CENTERS

A.W. Industries, Incorporated
 6788 N.W. 17th AVENUE
 Fort Lauderdale, FL 33309

SIZE: C
 SCALE: NONE
 DWG. NO.: 428-11-522
 SHEET: 1 OF 1

CUSTOMER DRAWING