

| Rev | Description | Date | By |
|-----|-----------------|----------|-----|
| A | INITIAL RELEASE | 09/15/05 | JSC |

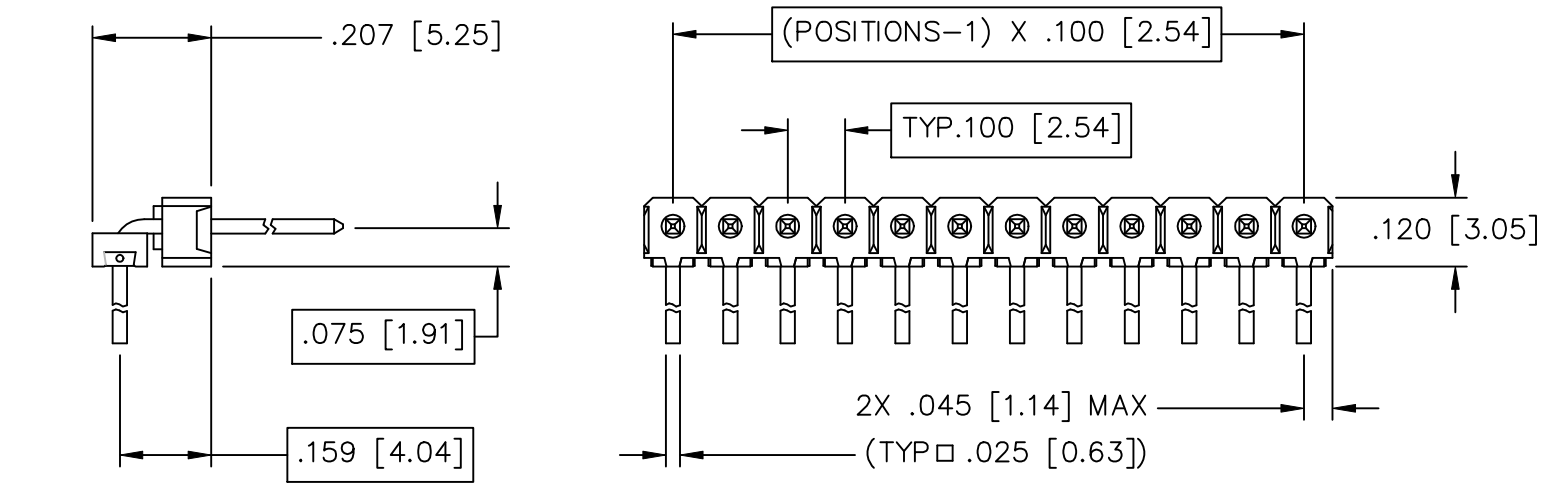
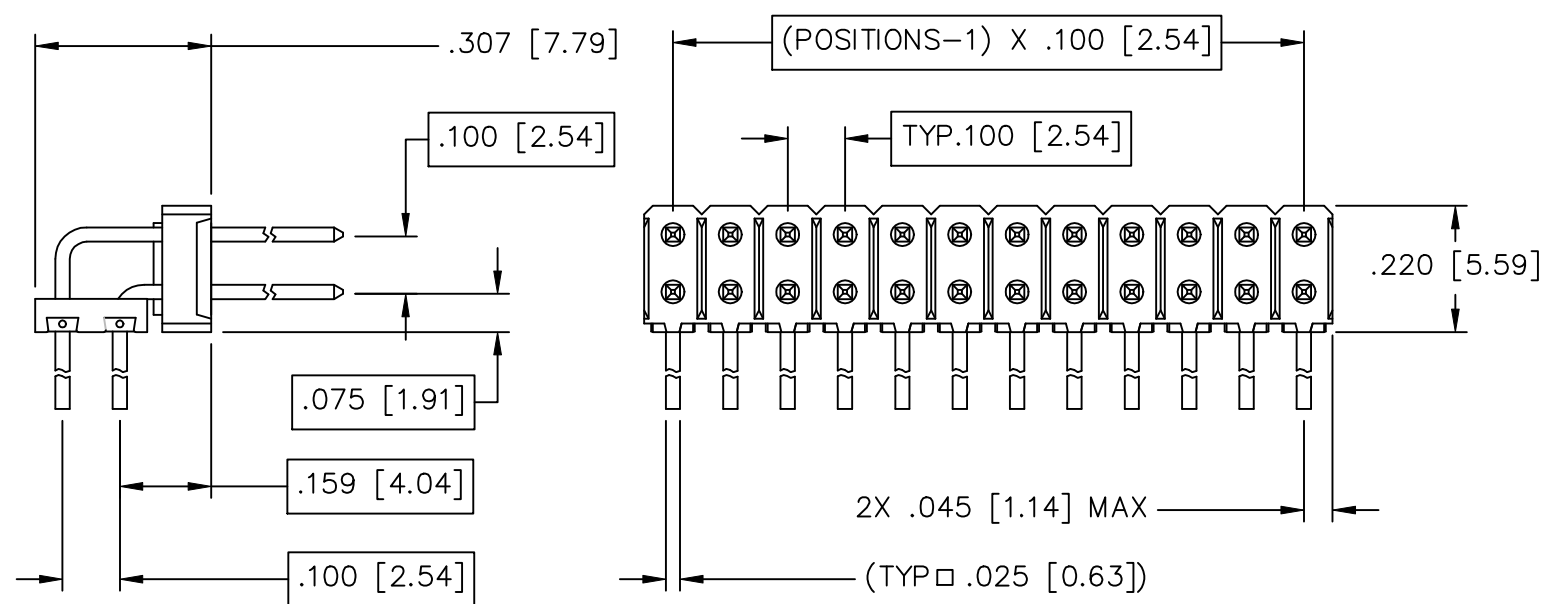

PART NUMBER DESCRIPTION

SERIES DESIGNATOR: ZR
 HEADER R/A - .100
 NUMBER OF ROWS: 1 - 1 ROW
 2 - 2 ROW
 POSITIONS PER ROW: 02 - 36
 POST LENGTH: A - .230 [5.84]
 B - .320 [8.13]
 MATING ZONE LENGTH: 1 - .165 [4.19]

DESIGN VARIATION: 00 - STANDARD
 SOLDER TAIL STYLE: S - STRAIGHT
 R - RETENTIVE
 SOLDER TYPE (SAC 305): N - NO-CLEAN FLUX
 M - SOLID CORE
 SOLDER TAIL LENGTH: C - .075 [1.90]

| CONTACT FINISH DESIGNATION ◁ 4 | | |
|--------------------------------|----------------------------|----------------------------|
| DESIGNATION | MATING ZONE | SOLDER TAIL |
| C | GOLD - FLASH | PURE TIN - 100 MICROINCHES |
| B | GOLD - 10 MICROINCHES | PURE TIN - 100 MICROINCHES |
| H | GOLD - 30 MICROINCHES | PURE TIN - 100 MICROINCHES |
| O | PURE TIN - 100 MICROINCHES | PURE TIN - 100 MICROINCHES |

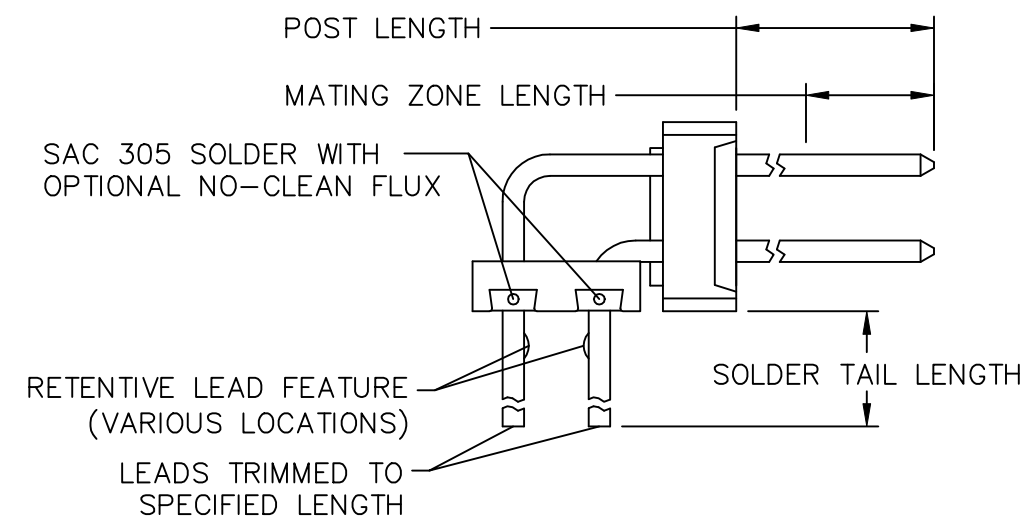



NOTES: UNLESS OTHERWISE SPECIFIED

- 1 INTERPRET THIS DRAWING IN ACCORDANCE WITH ASME Y14.5M - 1994
- 2 FOR OTHER SIZES, FINISHES, SOLDER VOLUMES OR ADDITIONAL DATA CONSULT TEKA CUSTOMER SERVICE DEPARTMENT
- 3 CONNECTOR SOLDER VOLUME BASED ON APPLICATION TO A .062±.007 [1.58±0.18] THICK PRINTED CIRCUIT BOARD
- 4 ALL TIN FINISHES ARE LOW STRESS / WHISKER MITIGATING

MATERIALS:

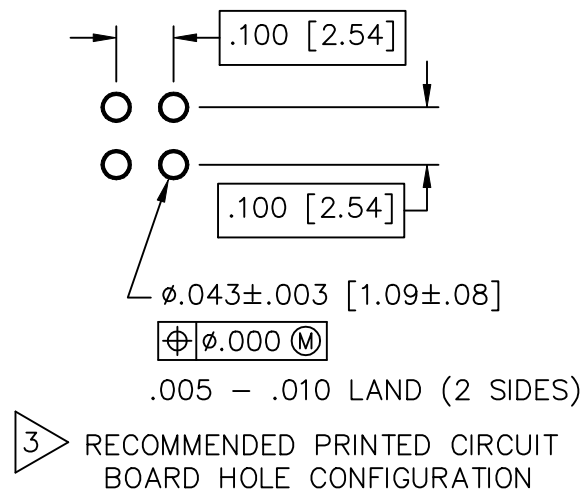
HOUSING: HIGH TEMPERATURE THERMOPLASTIC, UL RATED 94-V0
 CONTACT: COPPER ALLOY
 SOLDER: SEE PART NUMBER DESCRIPTION
 CONTACT FINISH: SEE PART NUMBER DESCRIPTION



| | | | |
|--|---|----------------|---|
| Unless otherwise specified: All dimensions are: Inches [mm] | Drawn by: J CACHINA | Date: 09/15/05 |  AN INTERPLEX INDUSTRIES CO. 100 PIONEER AVE WARWICK, R.I. 02888 TEL: (401) 785-4110 FAX: (401) 781-5730 E-MAIL: sales@teka.com HTTP://WWW.TEKA.COM |
| | Checked by: JSC Date: 09/15/05 | | |
| -Tolerances- No of places IN [mm] one ±.1 ±2,54 two ±.02 ±0,5 three ±.010 ±0,25 Angular ±2° | Title: R/A SB HEADER - .100 [2.54] PITCH (ROHS COMPLIANT) | | Part No: ZR____1____-00 |
| | Ref No: S20554 | Scale: 3:1 | Sheet 1 of 1 |