

TEKA
TKO™ PCB
Connectors

TKO features include BeCu contacts with LIF design, early engagement and high-temp plastic housing for SMT applications.

General Information

- Design provides low cost, highly reliable interconnection
- Ideal for mother/daughter board interconnections
- Mates with both .025 square or round pins
- Vertical or horizontal configurations
- Single or double row

Features

- Surface mount and solder tail configurations
- Designed for use with double-sided and multilayered PCB's
- High-temp. plastic allows infra-red and vapor phase soldering
- .145 ± .006 point-of-normal-force contact
- Low insertion force design
- BeCu contacts
- Selective gold plating
- Standoffs
- Packaging for robotic assembly available

Technical Data

- Current rating = 3 amp (maximum)
- Dielectric withstanding voltage = 1000 VAC RMS (minimum)
- Insulation resistance = 10,000 megaohms (minimum)
- Contact resistance = 30 milliohms (maximum)
- Contact retention = 2 lbs. (minimum)
- Durability = 200 mating cycles (minimum)
- Temperature ranges = - 65 degrees celsius to + 125 degrees celsius
- Mating force: = 4 oz./contact (maximum)

Test Data

- Specifications, prints and samples are available upon request from Teka Customer Service.

Ordering Information
 Part Number Codes



Series _____
 TKO

No. Positions/Row _____
 1 x 40 single row, vertical max.
 2 x 65 double row, vertical max.
 1 x 50 single row, horizontal max.
 2 x 65 double row, horizontal max.
 1 x 50 low profile vertical max.

Contact Material _____
 2 — BeCu

Insulator Material _____
 5 — high temp. thermo-plastic

Contact Finish _____
 2 — 10 microinches min. gold in contact interface and solder tail areas
 4 — 30 microinches min. gold in contact interface area and 100 microinches min. tin-lead alloy in solder tail area

** All over 50 microinches min. nickel underplate*

For additional plating options consult factory

Configurations _____
 101 — single row, vertical
 201 — double row, vertical
 103 — single row, horizontal
 203 — double row, horizontal
 104 — single row, horizontal, surface-mount
 204 — double row, horizontal, surface-mount
 161 — low profile, single row, vertical
 261 — low profile, double row, vertical
 269 — low profile, double row, vertical, surface-mount
 540 — rear entry, double row, surface-mount
 542 — rear entry, double row, thru-hole

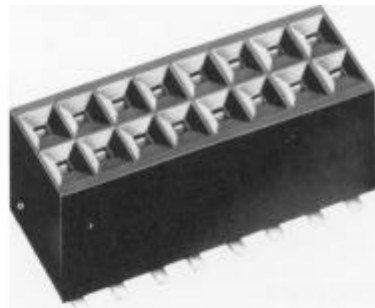

TKO™ PCB Connectors

Vertical Applications Standard vertical

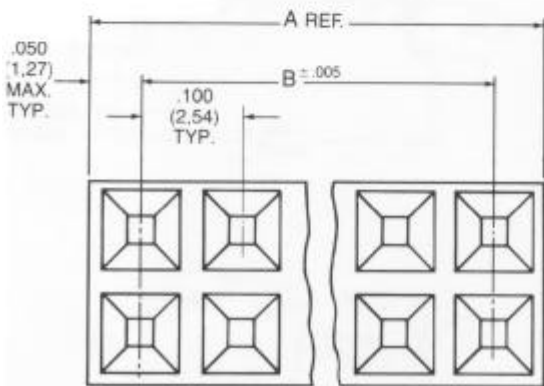

Single row, vertical (-101)

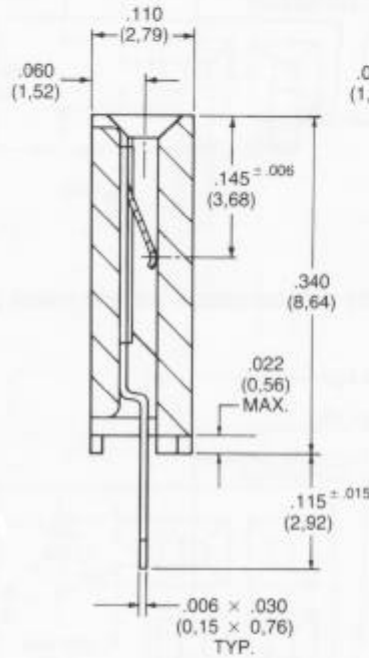

Double row, vertical (-201)

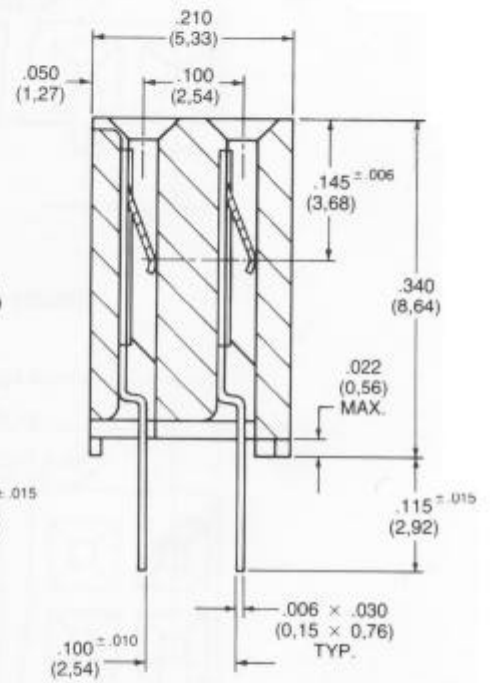

Low profile vertical

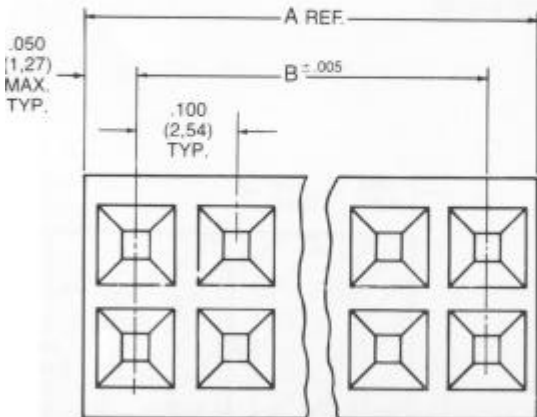

Single row, vertical (-161)

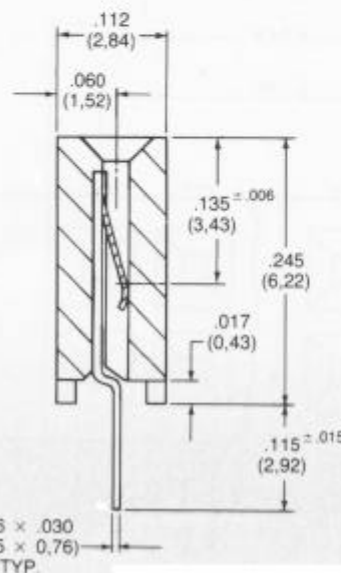

Double row, vertical (-261)

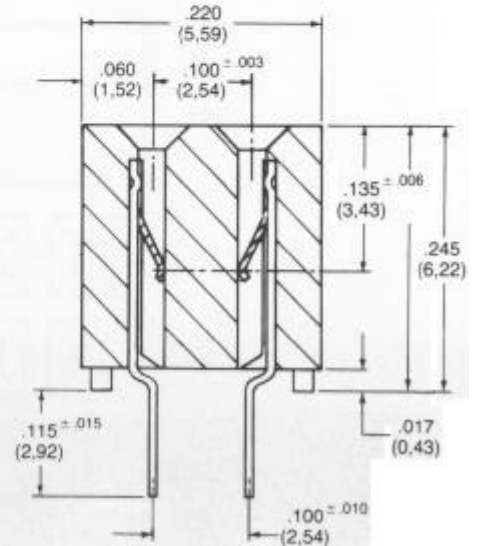

A = number of positions per row x .100" (2,54)
 $B \pm .005" = A - .100" (2,54)$