

Rev	Description	Date	By
E	ADDED M CONTACT LENGTH	04/04/05	JSC

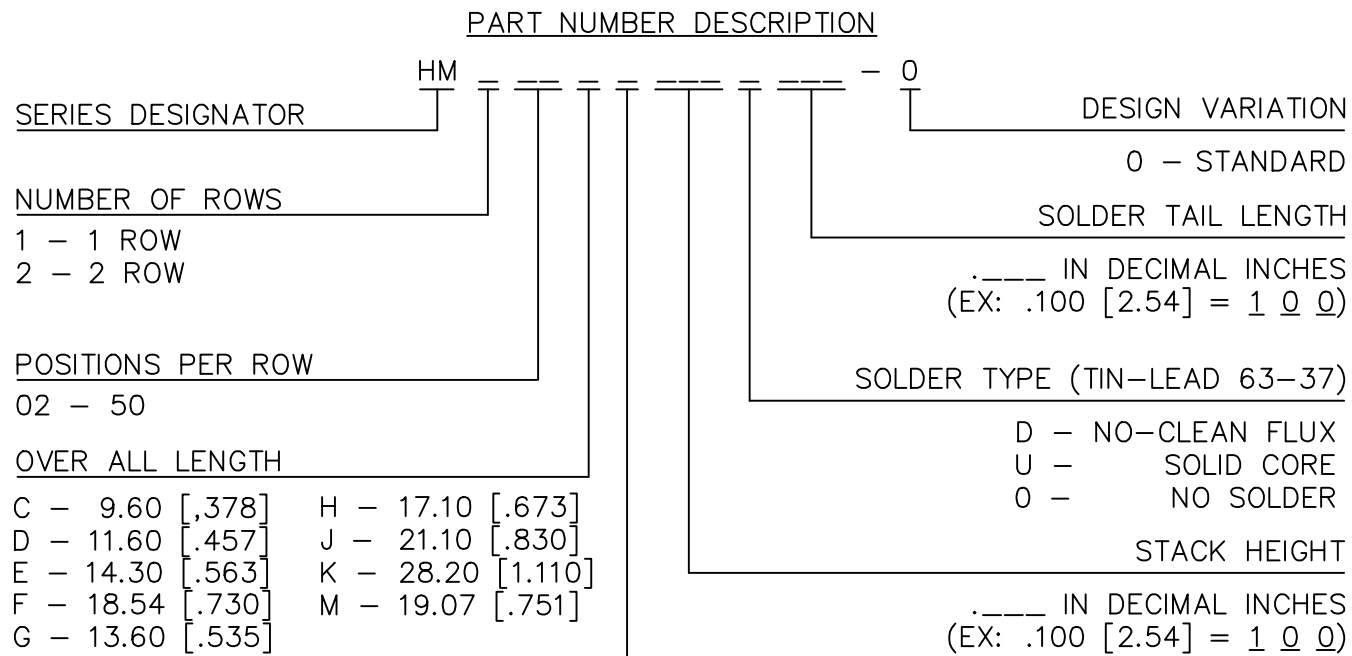

CONTACT FINISH DESIGNATION 4		
DESIGNATION	MATING ZONE	SOLDER TAIL
S	GOLD - FLASH	GOLD - FLASH
2	GOLD - 10 MICROINCHES	GOLD - 10 MICROINCHES
T	GOLD - FLASH	TIN-LEAD - 100 MICROINCHES
P	GOLD - 10 MICROINCHES	TIN-LEAD - 100 MICROINCHES
4	GOLD - 30 MICROINCHES MIN	TIN-LEAD - 100 MICROINCHES
K	TIN-LEAD - 100 MICROINCHES	TIN-LEAD - 100 MICROINCHES

- NOTES: UNLESS OTHERWISE SPECIFIED
- INTERPRET THIS DRAWING IN ACCORDANCE WITH ASME Y14.5M - 1994
 - FOR OTHER SIZES, FINISHES, SOLDER VOLUMES OR ADDITIONAL DATA CONSULT TEKA CUSTOMER SERVICE DEPARTMENT
 - CONNECTOR SOLDER VOLUME BASED ON APPLICATION TO A 1.58±0.18 [.062±.007] THICK PRINTED CIRCUIT BOARD
 - INDICATED DIMENSION APPLICABLE TO SELECTIVE CONTACT FINISHES ONLY

MATERIALS:

HOUSING: HIGH TEMPERATURE THERMOPLASTIC, UL RATED 94-VO

CONTACT: COPPER ALLOY

SOLDER: SEE PART NUMBER DESCRIPTION

CONTACT FINISH: (SEE PART NUMBER DESCRIPTION)

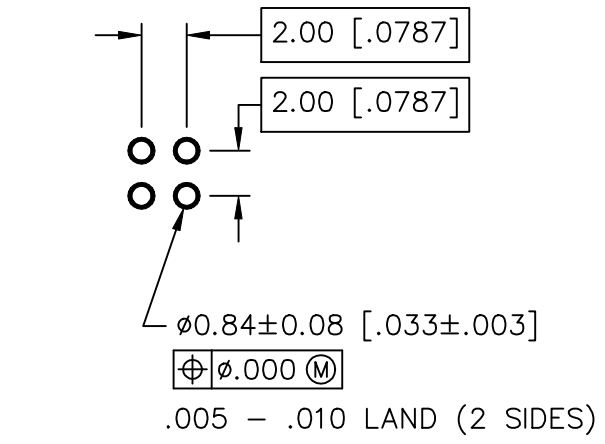

3 RECOMMENDED PRINTED CIRCUIT BOARD HOLE CONFIGURATION

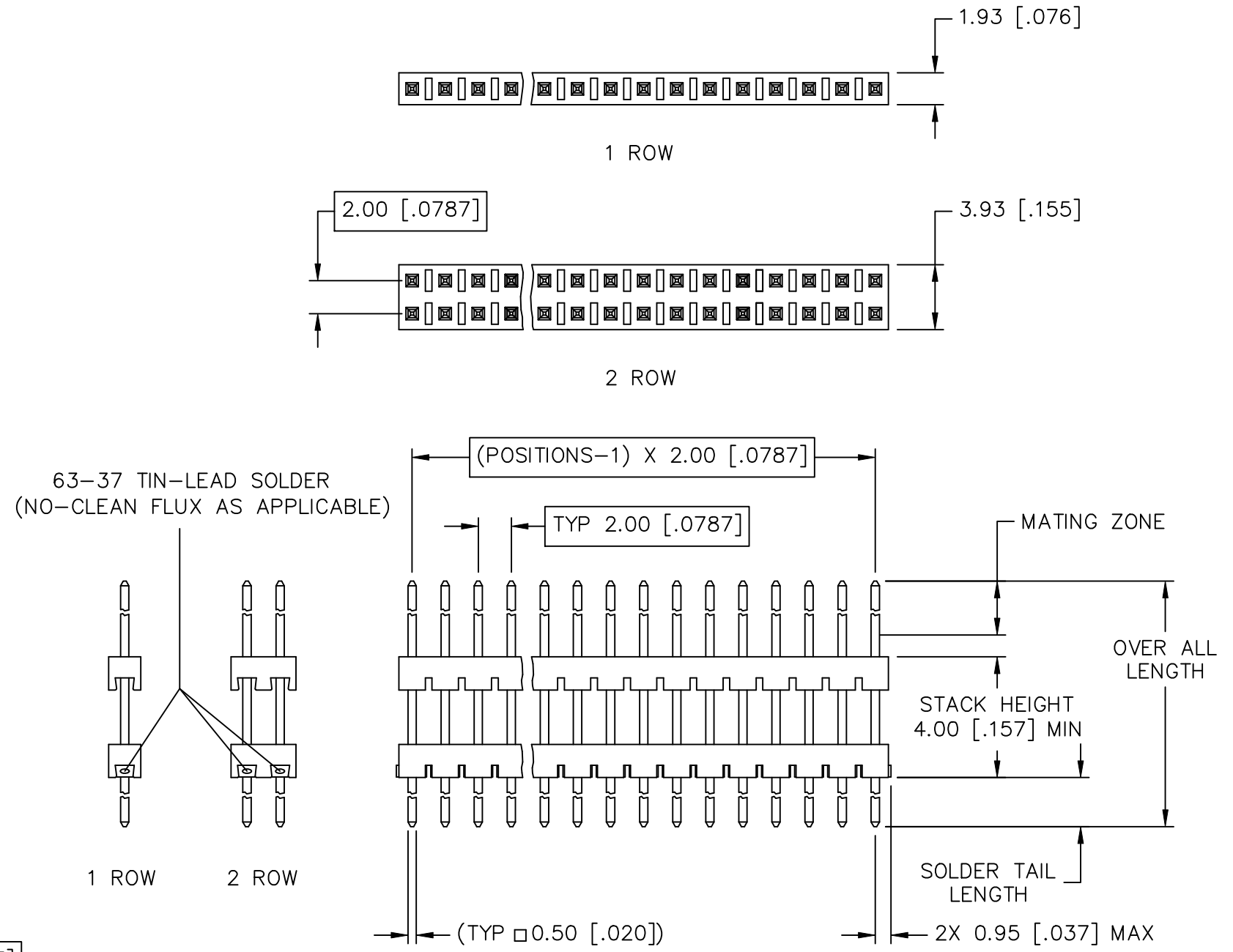

Unless otherwise specified: All dimensions are: mm [Inches]	Drawn by: J CACHINA	Date: 07/02/02	 AN INTERPLEX INDUSTRIES CO. 100 PIONEER AVE WARWICK, R.I. 02888 TEL: (401) 785-4110 FAX: (401) 781-5730 E-MAIL: sales@tekais.com
	Checked by: JSC	Date: 07/03/02	
No of places mm [IN] one ±0,5 ±.020 two ±0,25 ±.010 three ±0,13 ±.005	Title: SB STACKED HEADER - 2.00 MM PITCH		Part No: HM-----0
Angular ±2°	Ref No: S20241	Scale: 3:1	Sheet 1 of 1