

Rev	Description	Date	By
G	ADDED TYPE 3 PLATING	11/15/02	JSC

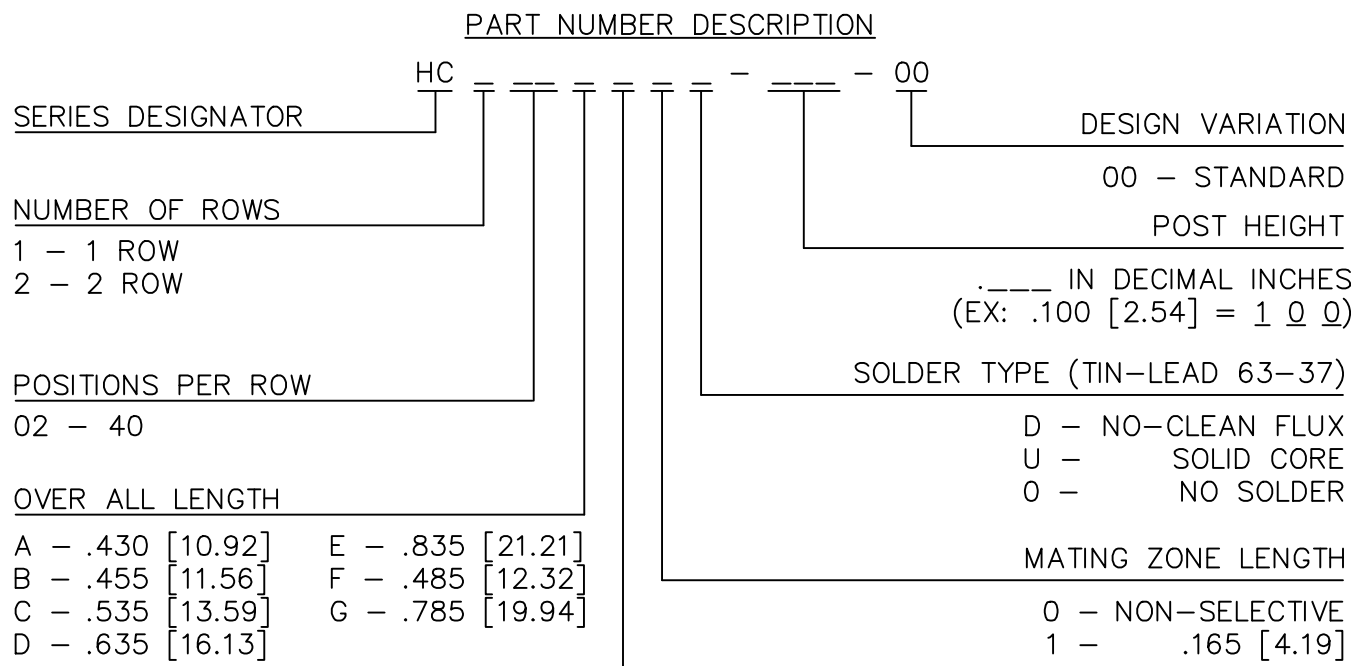

CONTACT FINISH DESIGNATION		
DESIGNATION	MATING ZONE	SOLDER TAIL
S	GOLD - FLASH	GOLD - FLASH
2	GOLD - 10 MICROINCHES	GOLD - 10 MICROINCHES
3	GOLD - 30 MICROINCHES	GOLD - 30 MICROINCHES
T	GOLD - FLASH	TIN-LEAD - 100 MICROINCHES
P	GOLD - 10 MICROINCHES	TIN-LEAD - 100 MICROINCHES
4	GOLD - 30 MICROINCHES MIN	TIN-LEAD - 100 MICROINCHES
K	TIN-LEAD - 100 MICROINCHES	TIN-LEAD - 100 MICROINCHES

- NOTES: UNLESS OTHERWISE SPECIFIED
- 1 INTERPRET THIS DRAWING IN ACCORDANCE WITH ASME Y14.5M - 1994
  - 2 FOR OTHER SIZES, FINISHES, SOLDER VOLUMES OR ADDITIONAL DATA CONSULT TEKA CUSTOMER SERVICE DEPARTMENT
  - 3 CONNECTOR SOLDER VOLUME BASED ON APPLICATION TO A .062±.007 [1.58±0.18] THICK PRINTED CIRCUIT BOARD

MATERIALS:

HOUSING: HIGH TEMPERATURE THERMOPLASTIC, UL RATED 94-VO

CONTACT: COPPER ALLOY

SOLDER: SEE PART NUMBER DESCRIPTION

CONTACT FINISH: (SEE PART NUMBER DESCRIPTION)

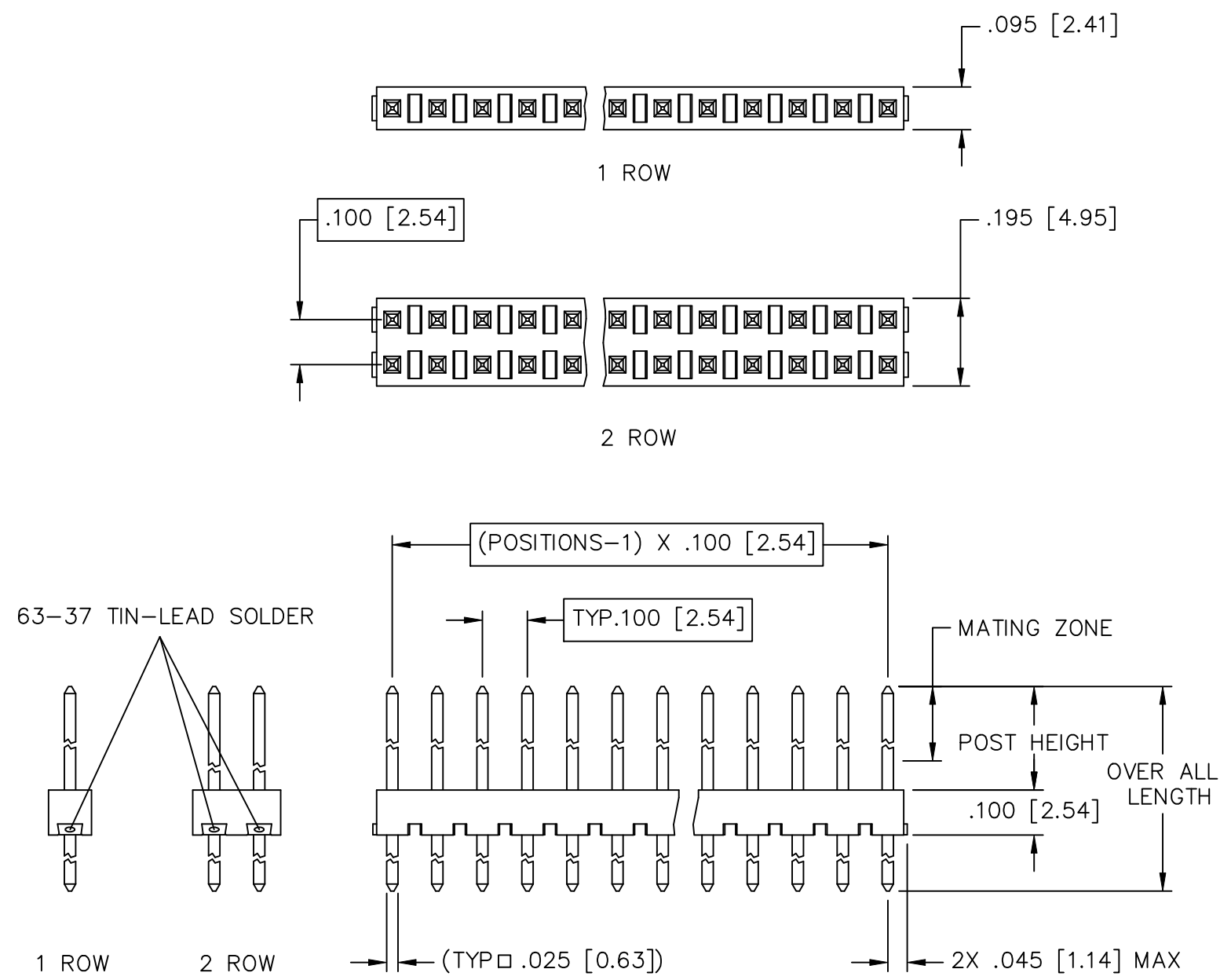
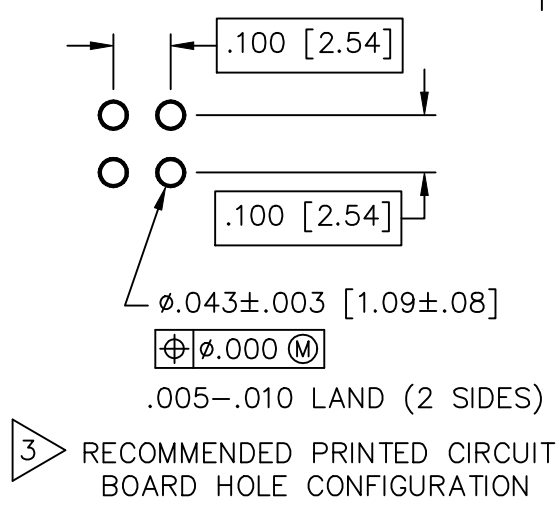

Unless otherwise specified: All dimensions are: Inches [mm]	Drawn by: J CACHINA	Date: 02/28/02	 AN INTERPLEX INDUSTRIES CO. 100 PIONEER AVE WARWICK, R.I. 02888 TEL: (401) 785-4110 FAX: (401) 781-5730 E-MAIL: sales@tekais.com
	Checked by: JSC    Date: 03/14/02		
-Tolerances- No of places IN [mm] one            ±.1            ±2,54 two            ±.02          ±0,5 three          ±.010        ±0,25  Angular ±2°	Title: SOLDER BEARING HEADER - .100 [2.54] PITCH		Part No: HC_____ - _____ - 00
	Ref No: S20207	Scale: 3:1	Sheet 1 of 1