

RECOMENDED HOLES LAYOUT

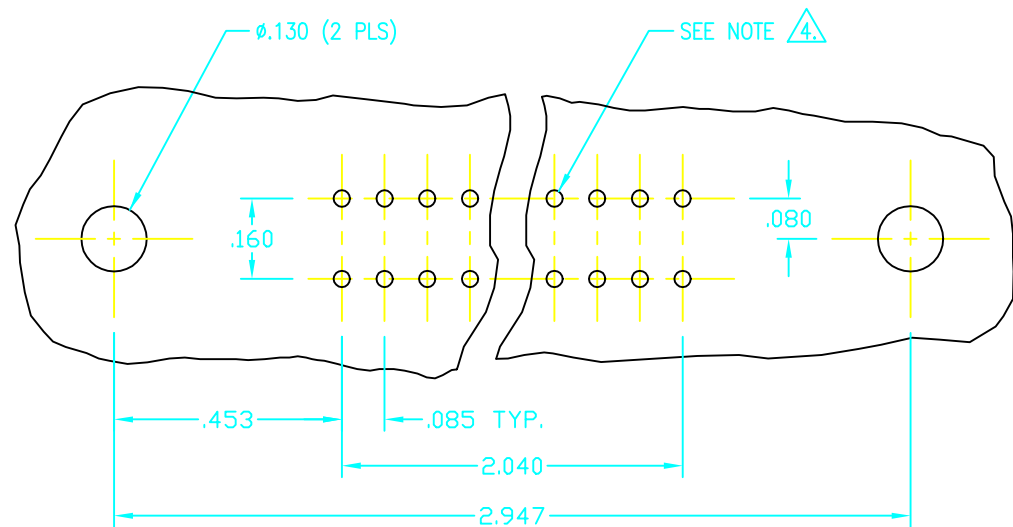

#4-40 THREADED INSERT

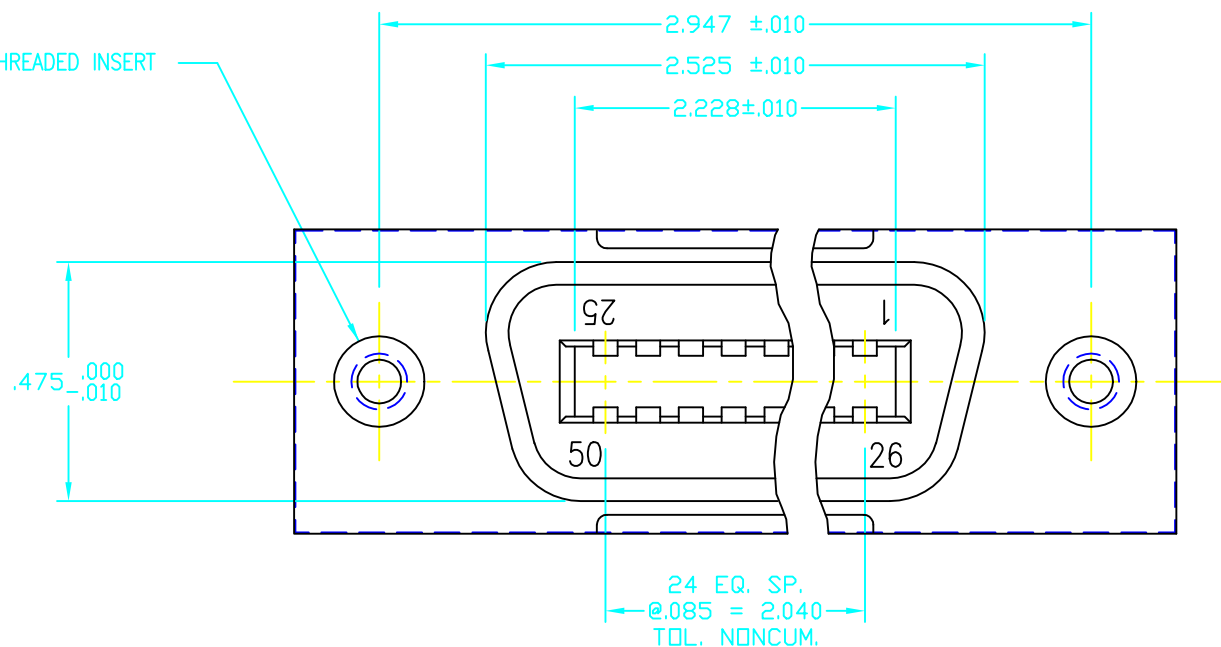

NOTES:

1. MATERIAL:
 - * INSULATOR - 30% GLASS REINFORCED THERMOPLASTIC POLYESTER (PBT) VALOX 420 SED OR EQUIVALENT UL 94V-0 RATED, COLOR - BLACK.
 - * CONTACT - PHOSPHORE BRONZE CDA 510.
 - * CONTACT PLATING - NICKEL PLATE .000050 MIN. THICK ALL OVER, GOLD PLATE .000030 MIN. THICK ON CONTACT AREA, .000100 MIN. SnPb OVER TAIL AND COMPLIANT AREA.
 - * SHELL - STEEL.
 - * SHELL PLATING - BRIGHT TIN ALL OVER.
2. ELECTRICAL CHARACTERISTICS:
 - * CONTACT RESISTANCE - 10 MILLIOHMS MAX.
 - * INSULATION RESISTANCE - 5000 MEGOHMS.
 - * WITHSTANDING VOLTAGE - 1000 VRMS
 - * CURRENT RAITING - 3 AMPERS MAX. PER CONTACT PAIR.
3. MECHANICAL CHARACTERISTICS:
 - * OPERATING TEMPERATURE - FROM -55°C TO +105°C.
 - * COMPLIANT SECTION INSERTION FORCE - 30 LB. MAX. PER CONTACT.
 - * COMPLIANT SECTION WITHDRAWAL FORCE - 10 LB. MIN. PER CONTACT.

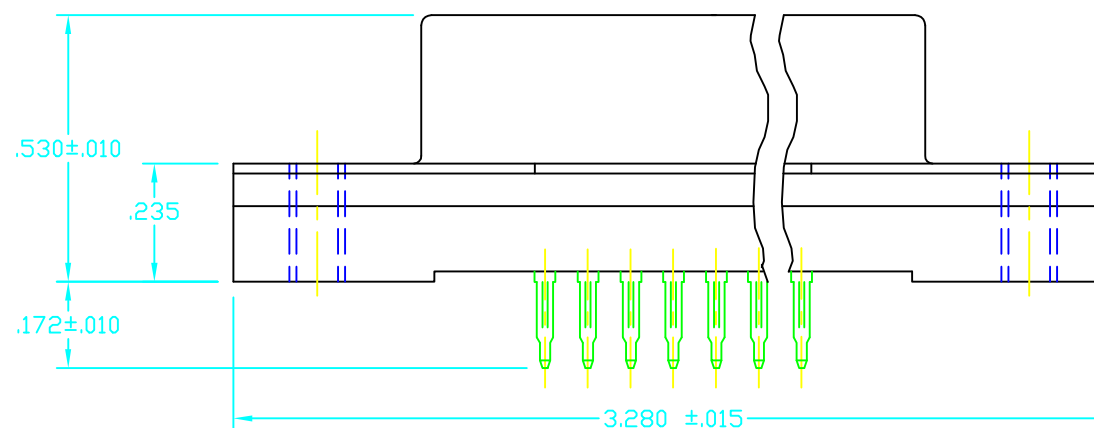
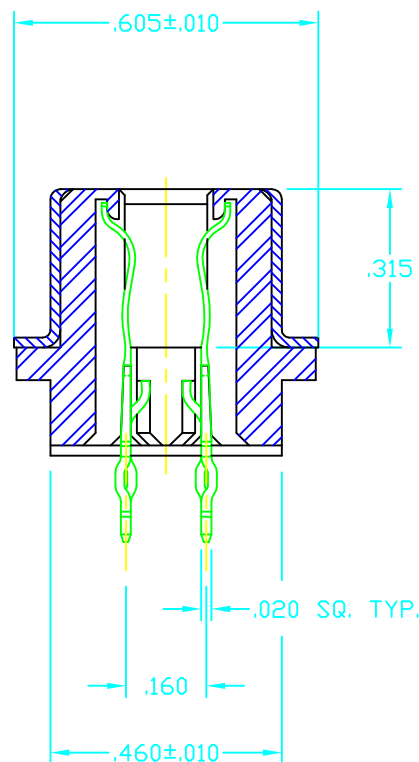

CUSTOMER DRAWING

4. PRINTED CIRCUIT BOARD HOLE INFORMATION:

- * BEFORE THRU-HOLE PLATING - .037-;-.039 DIA.
- * COPPER THRU-HOLE PLATING THICKNESS - .001-;-.002.
- * TIN-LEAD THRU-HOLE PLATING THICKNESS - .0003-;-.0012 PORE FREE.
- * FINISHED HOLE DIMENSION - .030-;-.035 DIA.

5. FLAT ROCK ASSEMBLE TO BACKPANEL, NO SPECIAL TOOLING REQUIRED.

REVISIONS			
REV	DESCRIPTION	DATE	APPROVED
A	INITIAL RELEASE (ESR1141)	01-23-98	JWM
1A	REVISED PER ESR 1894	01-24-00	JWM

APPROVED	
NAME	DATE
DRAWN JWM	01-98
CHECKED JMP	01-98
QUALITY DKJ	01-98
APPROVED JWM	01-98

THE INFORMATION, DATA AND/OR SPECIFICATIONS CONTAINED ON THIS DOCUMENT ARE PROPRIETARY TO A.W. INDUSTRIES AND MAY NOT BE COPIED, DUPLICATED OR DISCLOSED IN PART OR WHOLE WITHOUT AUTHORIZATION IN WRITING FROM A.W. INDUSTRIES.

ALL DIMENSIONS ARE IN INCHES.

TOLERANCES:
 DECIMAL .XX ±.015
 .XXX ±.005
 ANGLE ±1/2°

TITLE PRESS FIT CONNECTOR 50 PIN RECEPTACLE, SHIELDED	
A.W. Industries, incorporated 6788 N.W. 17th AVENUE Fort Lauderdale, FL 33309	
SIZE C	DWG. NO. 8650F-02-52P
SCALE NONE	ACAD FILE NO. 03-0605-1A SHEET 1 OF 1