

REVISIONS			
REV	DESCRIPTION	DATE	APPROVED
A	INITIAL RELEASE (ESR 0634)	10-29-96	JWM

**NOTES:**

**1. MATERIALS AND FINISH:**

INSULATOR- GLASS FILLED THERMO-PLASTIC  
 POLYESTER, 94V-0 RATED, BLACK.  
 CONTACTS- CDA 725  
 CONTACT PLATING- .000030 AU OVER .000050 Ni ON  
 CONTACT POINT, TAIL .000100 MATE FINISH 60/40 SnPb

**2. ELECTRICAL CHARACTERISTICS:**

CONTACT RESISTANCE:  
 CONTACT TO DAUGHTER CARD- 10 MILLIOMHS .  
 OPERATING VOLTAGE- 1800 VDC.  
 INSULATION RESISTANCE- 5000 MEGOHMS.  
 CONTACT CURRENT RATING- 5 AMPS AT 30C.

**3. MECHANICAL CHARACTERISTICS:**

OPERATING TEMPERATURE- -55 TO +125C.  
 DURABILITY- PER BELLCORE TR-NWT-000078.

MARKING AS SHOWN.

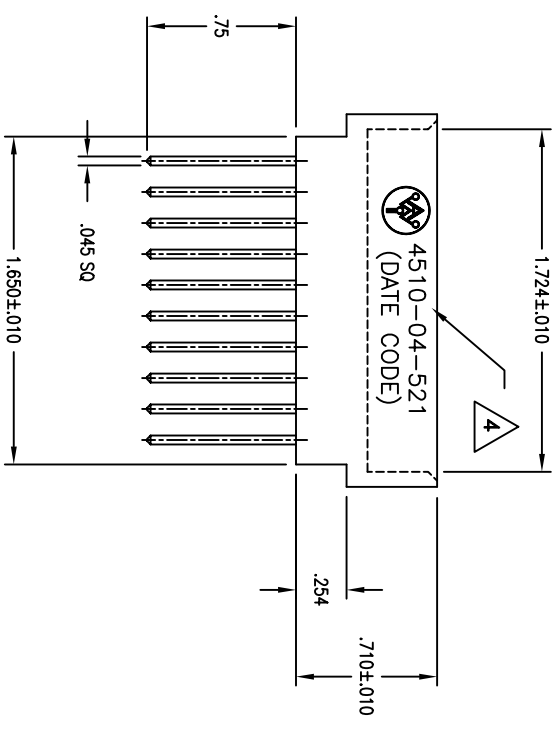
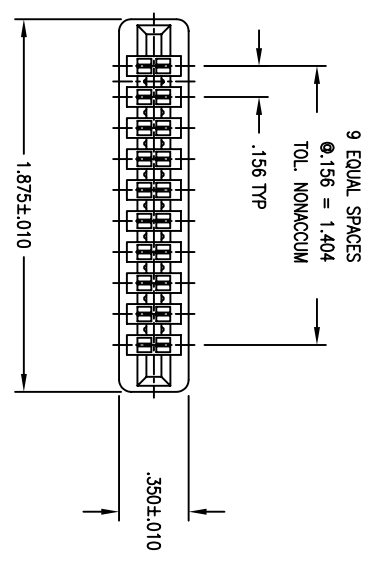
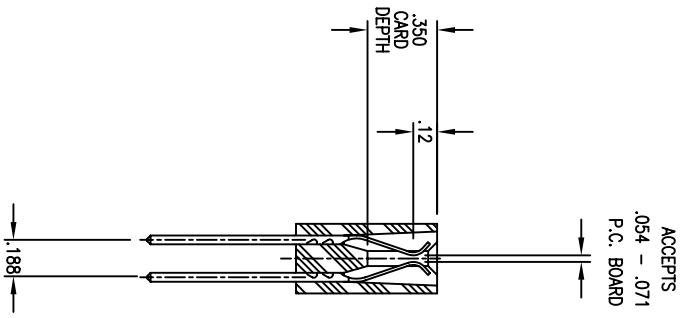

**CUSTOMER DRAWING**

APPROVED	
NAME	DATE
DRWEN JWM	10-96
CHECKED YL	10-96
QUALITY WBK	10-96
APPROVED JWM	10-96

ALL DIMENSIONS ARE IN INCHES.  
 TOLERANCES:  
 DECIMAL .XX ±.015  
 .XXX ±.005  
 ANGLE ±1/2'

THE INFORMATION, DATA AND/OR SERVICES CONTAINED ON THIS DRAWING ARE PROPRIETARY TO A.W. INDUSTRIES AND MAY NOT BE COPIED, REPRODUCED OR DISCLOSED IN ANY MANNER WITHOUT THE WRITTEN PERMISSION OF A.W. INDUSTRIES.

**A.W. Industries, Incorporated**  
 6788 N.W. 17th AVENUE  
 Fort Lauderdale, FL 33309

**CARD EDGE CONNECTOR .156 X .188**  
 10 POSITIONS, .045 SQ.

SIZE C  
 SCALE NONE  
 ACAD FILE NO. 03-0398-0A  
 SHEET 1 OF 1