

REVISIONS

REV	DESCRIPTION	DATE	APPROVED
A	INITIAL RELEASE (ESR 0650)	11-08-96	JWM
B	INITIAL RELEASE (ESR 90436)	11-11-97	JWM
C	REVISED (ESR 1830)	09-22-99	JWM

NOTES:
1. MATERIAL:
 INSULATOR MATERIAL - GLASS FILLED THERMO-PLASTIC
 POLYESTER, 94V-0 RATED, BLACK.
 CONTACT MATERIAL - CDA 510.
 CONTACT PLATING - .000030 Au OVER .000050 Ni ON
 CONTACT POINT, TAIL AND COMPLIANT SECTION .000100
 MATTE FINISH 60/40 SnPb.

2. ELECTRICAL CHARACTERISTICS:
 CONTACT RESISTANCE:
 CONTACT TO DAUGHTER CARD - 10 MILLIOHMS.
 COMPLIANT SECTION TO P.I.H. - 2MILLIOHMS.
 DIELECTRIC WITHSTANDING VOLTAGE - 1800 VAC.
 INSULATION RESISTANCE - 5000 MEGOHMS.
 CONTACT CURRENT RATING - 3 AMPS AT 30°C.

3. MECHANICAL CHARACTERISTICS:
 OPERATING TEMPERATURE - -55° TO +125°C.
 DURABILITY - PER BELLCORE TR-NWT-000078.
 INSERTION FORCE - COMPLIANT SECTION 40 lbs
 MAXIMUM PER CONTACT.
 WITHDRAWAL FORCE - COMPLIANT SECTION 10 lbs
 MINIMUM PER CONTACT.

HOLE SIZE REQUIREMENTS:
 DRILLED HOLE DIA: .0533±.001
 COPPER PLATING: .001 TO .003
 TIN-LEAD PLATING: .0001 TO .0008
 FINISHED HOLE DIA: .047±.003

4 FLAT ROCK ASSEMBLE TO BACKPANEL
 NO SPECIAL TOOL REQUIRED.
 BACKPANEL MIN. THICKNESS TO BE .093.

5 .300 AND .350 CARD SLOT DEPTH CONTROLLED
 BY THESE SURFACES ONLY.

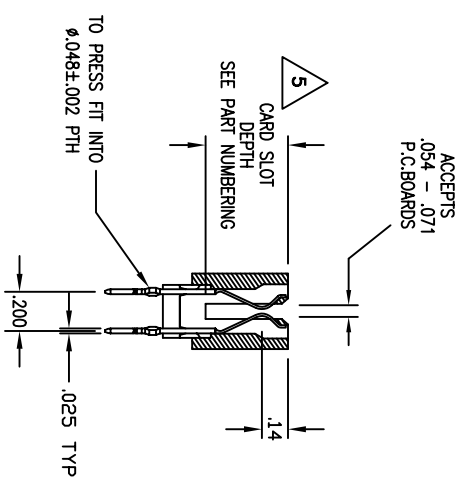

ACCEPTS
 .054 - .071
 P.C. BOARDS

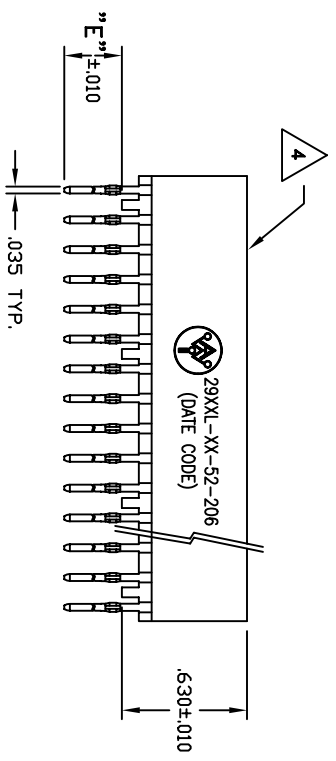
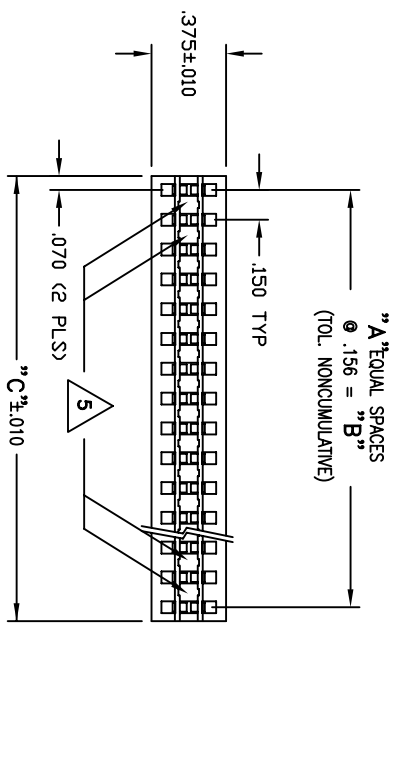

DIMENSIONS

A	NUMBER OF EQUAL SPACES (TO DETERMINE, SUBTRACT 1 FROM THE NUMBER OF DESIRED DUAL CONTACT POSITIONS)
B	NUMBER OF EQUAL SPACES X .150
C	NUMBER OF EQUAL SPACES X .150 + .140
E	TAIL LENGTH: SEE PART NUMBERING

PART NUMBERING

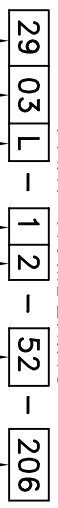

SERIES CODE
 .150 X .200
 NUMBER OF DUAL POSITIONS
 02 THROUGH 43
 BODY STYLE
 L - WITHOUT CARD SCOOPS

VARIATION CODE:
 BOTH ENDS OPEN.
 PLATING CODE (SEE NOTES)
 Contact factory for other options.

TAIL LENGTH (E DIMENSION)
 1 - .190
 2 - .375
 3 - .465
 4 - .600

CARD SLOT DEPTH (SEE NOTE 5)
 1 - .415
 2 - .350
 3 - .300

CUSTOMER DRAWING

TITLE
 COMPLIANT PIN PRESS FIT CARD EDGE CONNECTOR
 .150 X .200 CENTERS, .630 HIGH, BOTH ENDS OPEN

A.W. Industries, Incorporated
 6788 N.W. 17th AVENUE
 Fort Lauderdale, FL 33309

APPROVED

NAME	DATE
JWM	11-96
JWM	11-96
WBK	11-96
JWM	11-96

THE INFORMATION, DATA AND/OR SERVICES CONTAINED ON THIS DRAWING ARE PROPRIETARY TO A.W. INDUSTRIES AND MAY NOT BE COPIED, REPRODUCED OR DISCLOSED IN ANY MANNER WITHOUT THE WRITTEN PERMISSION OF A.W. INDUSTRIES.

ALL DIMENSIONS ARE IN INCHES.

TOLERANCES:
 DECIMAL .XX ±.015
 .XXX ±.005
 ANGLE ±1/2°

SIZE **C**

SCALE NONE

DATE FILE NO. 03-0410-0C

SHEET 1 OF 1