

REVISIONS		
REV	DESCRIPTION	DATE
A	INITIAL RELEASE	08-17-93
		APPROVED JWM

NOTES:

1. MATERIALS AND FINISH:

INSULATOR - GLASS FILLED THERMO-PLASTIC
POLYESTER, 94V-0 RATED, BLACK

CONTACTS - PHOSPHOR BRONZE

CONTACT PLATING - .000030 AU OVER .000050 NI ON
CONTACT POINT, TAIL .000100 MATE FINISH 60/40 SnPb

2. ELECTRICAL CHARACTERISTICS:

CONTACT RESISTANCE:

CONTACT TO DAUGHTER CARD - 10 MILLIOMHS.

DIELECTRIC WITHSTANDING VOLTAGE - 1000 VAC.

INSULATION RESISTANCE - 5000 MEGOHMS.

CONTACT CURRENT RATING - 3 AMPS AT 30°C.

3. MECHANICAL CHARACTERISTICS:

OPERATING TEMPERATURE - -55° TO +125°C.

DURABILITY - PER BELLORE TR-NWT-000078.

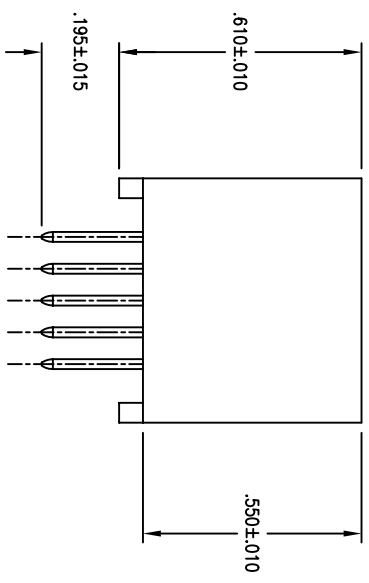
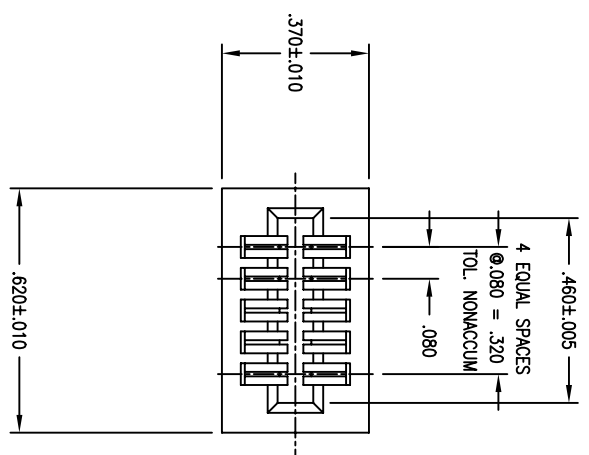
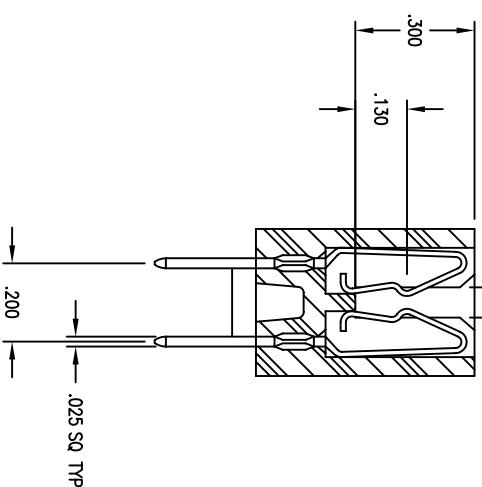

APPROVED	
NAME	DATE
DESIGN JWM	08-93
CHECKED DTR	08-93
QUALITY DTR	08-93
APPROVED JWM	08-93

THE INFORMATION, DATA AND/OR SERVICES CONTAINED ON THIS DRAWING ARE PROPRIETARY TO A.W. INDUSTRIES AND MAY NOT BE COPIED, REPRODUCED OR DISCLOSED IN ANY MANNER WITHOUT THE WRITTEN PERMISSION OF A.W. INDUSTRIES.

ALL DIMENSIONS ARE IN INCHES.

DECIMAL .XX ±.015
.XXX ±.005

ANGLE ±1/2°

TITLE

CARD EDGE CONNECTOR
.080 X .200 CENTERS

A.W. Industries, Incorporated
6788 N.W. 17th AVENUE
Fort Lauderdale, FL 33309

SIZE C
SCALE 2/1
DWG. NO. 2605-52
ACAD FILE NO. 03-0140-0A
SHEET 1 OF 1