

NOTES:

1. MATERIAL:

INSULATOR MATERIAL - GLASS FILLED THERMO-PLASTIC POLYESTER, 94Y-0 RATED, BLACK.
 CONTACT MATERIAL - CDA 510.
 CONTACT PLATING - .000030 Au OVER .000050 Ni ON CONTACT POINT, TAIL AND COMPLIANT SECTION .000100 MATTE FINISH 60/40 SnPb.

2. ELECTRICAL CHARACTERISTICS:

CONTACT RESISTANCE - CONTACT TO DAUGHTER CARD - 10 MILLIOHMS, COMPLIANT SECTION TO P.T.H. - 2MILLIOHMS.
 DIELECTRIC WITHSTANDING VOLTAGE - 1800 VAC.
 INSULATION RESISTANCE - 5000 MEGOHMS.
 CONTACT CURRENT RATING - 3 AMPS AT 30°C.

3. MECHANICAL CHARACTERISTICS:

OPERATING TEMPERATURE - -55° TO +125°C.
 DURABILITY - PER BELLCORE TR-NWT-000078.
 INSERTION FORCE - COMPLIANT SECTION 40 lbs MAXIMUM PER CONTACT.
 WITHDRAWAL FORCE - COMPLIANT SECTION 10 lbs MINIMUM PER CONTACT.
 HOLE SIZE REQUIREMENTS - DRILLED HOLE DIA. .0453±.001, PLATING: .001 TO .003 COPPER AND .0001 TO .0008 SOLDER.
 FINISHED HOLE DIA. .040±.003.

- 4 FLAT ROCK ASSEMBLE TO BACKPANEL NO SPECIAL TOOL REQUIRED. BACKPANEL MIN. THICKNESS TO BE .093. .300 AND .350 CARD SLOT DEPTH CONTROLLED BY THESE SURFACES ONLY.
- 5

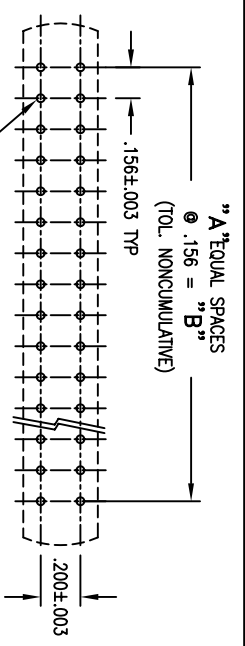

RECOMMENDED PCB LAYOUT

ACCEPTS
 .054 - .071
 P.C. BOARDS

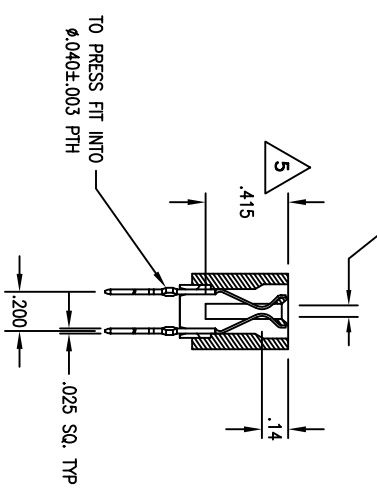

DIMENSIONS

	(TO DETERMINE, SUBTRACT 1 FROM THE NUMBER OF DESIRED DUAL CONTACT POSITIONS)
A	NUMBER OF EQUAL SPACES X .156
B	NUMBER OF EQUAL SPACES X .156
C	NUMBER OF EQUAL SPACES X .156 + .312
D	NUMBER OF EQUAL SPACES X .156 + .442
E	TAIL LENGTH: SEE PART NUMBERING

CUSTOMER DRAWING

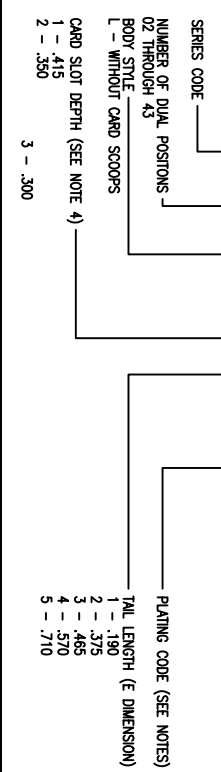

REV	DESCRIPTION	DATE	APPROVED
A	INITIAL RELEASE (ESR 0351)	01-26-96	JWM
B	REVISED (ESR 1804)	08-18-99	JWM

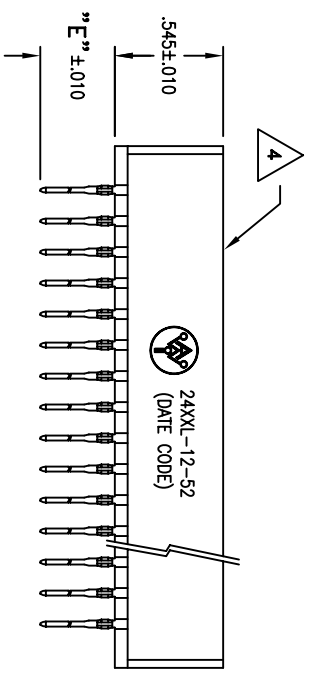
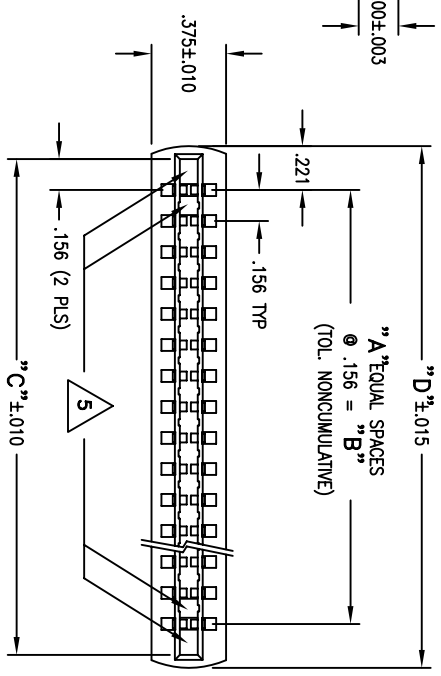

RECOMMENDED DAUGHTER BOARD

APPROVED	
NAME	DATE
JWM	01-96
YL	01-96
WBK	01-96
JWM	01-96

ALL DIMENSIONS ARE IN INCHES.
 TOLERANCES:
 DECIMAL .XX ±.015
 .XXX ±.005
 ANGLE ±1/2°

THE INFORMATION, DATA AND/OR SERVICE CONTAINED ON THIS DRAWING IS THE PROPERTY OF A.W. INDUSTRIES AND MAY NOT BE COPIED, REPRODUCED OR DISCLOSED IN ANY MANNER WITHOUT THE WRITTEN PERMISSION OF A.W. INDUSTRIES.

A.W. Industries, Incorporated
 6788 N.W. 17th AVENUE
 Fort Lauderdale, FL 33309

COMPLIANT PIN PRESS FIT CARD EDGE CONNECTOR, 156 X 200 CENTERS

24XXL-XX-52

SCALE NONE

DATE FILE NO. 03-0304-0B

SHEET 1 OF 1