

REVISIONS		
REV	DESCRIPTION	DATE
A	PRELIMINARY	07-08-94
		APPROVED JWM

NOTES:

1. MATERIALS AND FINISH:

INSULATOR- GLASS FILLED THERMO-PLASTIC
 POLYESTER, 94V-0 RATED, BLACK.
 CONTACTS- CDA 725
 CONTACT PLATING- .000030 Au OVER .000050 Ni ON
 CONTACT POINT, TAIL .000100 MATTE FINISH 60/40 SnPb.

2. ELECTRICAL CHARACTERISTICS:

CONTACT RESISTANCE:
 CONTACT TO DAUGHTER CARD- 10 MILLIOHMS.
 OPERATING VOLTAGE- 1500 VDC
 INSULATION RESISTANCE- 5000 MEGOHMS.
 CONTACT CURRENT RATING- 5 AMPS AT 30°C.

3. MECHANICAL CHARACTERISTICS:

OPERATING TEMPERATURE- -55 TO +125°C.
 DURABILITY- PER BELLCORE TR-NW-000078.
 INSERTION FORCE- 16 OZ MAX PER CONTACT
 WITH .036 THICK TEST BLADE.
 WITHDRAWAL- 2 OZ MIN PER CONTACT
 WITH .027 THICK TEST BLADE.
 PUSHOUT FORCE- 8 LBS MIN PER CONTACT.

4 MARKING AS SHOWN.

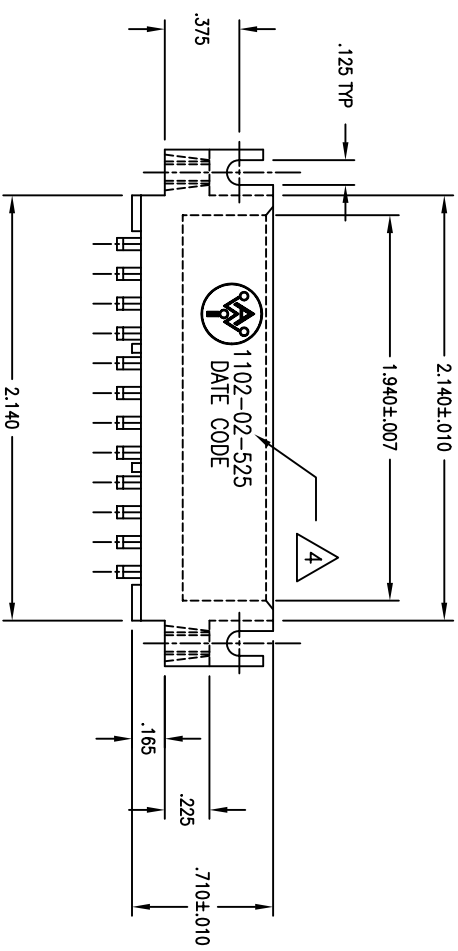
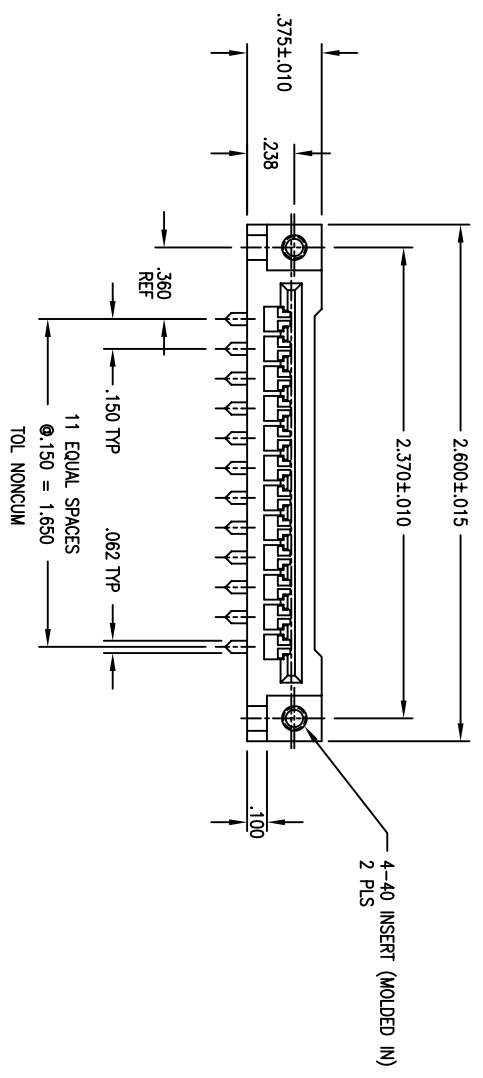
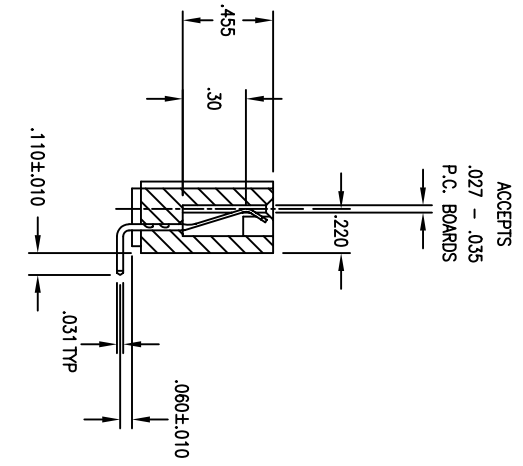

CUSTOMER DRAWING
 CUSTOMER NAME P/N 1102-02-525

APPROVED	
NAME	DATE
DRAWN JWM	07-94
CHECKED JWM	07-94
QUALITY CBW	07-94
APPROVED JWM	07-94

ALL DIMENSIONS ARE IN INCHES.
 TOLERANCES:
 DECIMAL .XX ±.015
 .XXX ±.005
 ANGLE ±1/2°

THE INFORMATION, DATA AND/OR SERVICES CONTAINED ON THIS DRAWING ARE PROPRIETARY TO A.W. INDUSTRIES AND MAY NOT BE COPIED, REPRODUCED OR DISCLOSED IN ANY MANNER WITHOUT THE WRITTEN PERMISSION OF A.W. INDUSTRIES.

A.W. Industries, Incorporated
 6788 N.W. 17th AVENUE
 Fort Lauderdale, FL 33309

CARD EDGE CONNECTOR .150 CENTERS
 SINGLE ROW, RIGHT ANGLE

SIZE C
 SCALE NONE
 DWG. NO. 1102-02-525
 SHEET 1 OF 1